



DR. BUU NYGREN *PRESIDENT*
RICHELLE MONTOYA *VICE PRESIDENT*

The Navajo Nation | Yideeskáądi Nitsáhákees

January 5, 2024

Naschitti Community Governance
Drawer D
Sheepsprings New Mexico, 87364

ATTENTION: Rhonda Herber, Commission President

REFERENCE: 164 Review 020787 / Contract

Dear : Ms. Herber

Attached please find your copy of the approved Contract (CO16298) with the Navajo Nation Office of the President and Vice President. The Contract has been awarded in the amount of \$1,146,748.70. The term of the contract will commence on October 23, 2023, and expires September 30, 2026.

Reference above contract number on all invoices, documents, and correspondence as it relates to this contract.

Should you have any questions, please contact Arnold D. Jake at 928.309.5534.

Sincerely,

A handwritten signature in blue ink, appearing to read "Darlene Begay".

Darlene Begay, Senior Accountant
OOC – Contract Administration

xc: Arnold D. Jake, Navajo Nation OPVP
Joseph Kaulaity, CA / Navajo Nation Office of the Controller
Contract Folder: CO16298

**SUBRECIPIENT AGREEMENT
BETWEEN
THE NAVAJO NATION AND NASCHITTI COMMUNITY GOVERNANCE
FOR
SUBAWARD OF AMERICAN RESCUE PLAN ACT FISCAL RECOVERY FUNDS
FOR PURPOSES OF BATHROOM ADDITION (1.14), RURAL ADDRESSING (1.14),
HOUSING WIRING (2.18)**

Name of Subrecipient Naschitti Community Governance	Phone Number 505-732-5400
Name and Title of Person Authorized to accept funding for the Subrecipient (“Designated Official”) Rhonda Herbert, Commission President	Designated Official’s Email Address rherbert@naataanii.org
Subrecipient’s Mailing Address Drawer D Sheep Springs, NM 87364	
Subrecipient’s Employer Identification Number 85-0400218	
Subrecipient’s DUNS Number & Unique Entity Identifier (“UEI”) Number	
Federal Awarding Agency; Assistance Listing Number & Title; Federal Award Date U.S. Department of Treasury; 21.027; May 27, 2021	
Expenditure Plan Title: Bathroom Addition (1.14); Rural Addressing (1.14); House Wiring (2.18)	
Period of Performance See Paragraph 5(b)	Amount of Subaward and Business Units \$1,146,748.00; K2115145; K2115146; K2115153

This Subrecipient Agreement includes and incorporates:

1. Terms and Conditions;
2. Appendix A – Scope of Work
3. Appendix B – Budget
4. Appendix C – Disbursement Schedule
5. Appendix D – Expenditure Plan
6. Appendix E — Council Resolution Approving Expenditure Plan
7. Appendix F – Financial Assistance Agreement between Department of Treasury and The Navajo Nation
8. Appendix G - U.S. Department of Treasury Compliance and Reporting Guidance for SLFRF

A complete Subrecipient Agreement, including all Appendices, must be submitted prior to disbursement of the awarded Navajo Nation Fiscal Recovery Funds (“Subaward Funds”).

TERMS AND CONDITIONS

This Subrecipient Agreement (“Agreement”) is made and entered into by and between the Navajo Nation, hereinafter called the “**NATION**” and the “Nazlini Chapter” hereinafter called the “**SUBRECIPIENT.**” Collectively, the **NATION** and the **SUBRECIPIENT** are the “**PARTIES.**”

WHEREAS, the U.S. Department of the Treasury (“Treasury”) has allocated to the **NATION** funding from the Coronavirus State and Local Fiscal Recovery Fund under Section 603(b) of the Social Security Act, as amended by Section 9901 of the American Rescue Plan Act (“ARPA”), for the limited purposes identified in the Interagency Agreement between Treasury and the **NATION**, identified as Appendix F, the Coronavirus State and Local Fiscal Recovery Funds Final Rule (“Final Rule”) and other Treasury guidance in the form of Frequently Asked Questions, and the Compliance and Reporting Guidance for SLFRF (“Compliance and Reporting Guidance”), identified as Appendix G, all of which are incorporated herein by this reference.

WHEREAS, the ARPA authorizes the **NATION** to expend the Fiscal Recovery Funds (“FRF”) awarded to the **NATION** for the following eligible purposes as outlined in the Final Rule as follows:

- (1) To respond to the COVID-19 public health emergency or its negative economic impacts, including assistance to households, small businesses, and nonprofits, or aid to impacted industries such as tourism, travel, and hospitality;
- (2) To respond to workers performing essential work during the COVID-19 public health emergency by providing premium pay to eligible workers;
- (3) For the provision of government services to the extent of the reduction in revenue due to the COVID-19 public health emergency relative to revenues collected in the most recent full fiscal year prior to the emergency; and
- (4) To make necessary investments in water, sewer, or broadband infrastructure.

WHEREAS, the **PARTIES** desire to enter into this Agreement so that the **NATION** may provide a subaward of FRF for appropriate and qualifying expenditures of FRF to execute projects or programs outlined in the Expenditure Plan approved by the **NATION** through Council Resolution CAP-20-23 as specified in **Appendix D.**

NOW, THEREFORE, in consideration of the foregoing recitals which are incorporated herein by reference, and the terms and conditions set forth below, the **PARTIES** agree as follows:

1. **Definitions.**

- a. “Disburse / Disbursement” is defined as when the Office of the Controller (“OOC”) issues a check or initiates the transfer of Funds into the **SUBRECIPIENT’S** account.
- b. “Expenditure Plan” is the **SUBRECIPIENT’S** Fiscal Recovery Funds Request Form and Expenditure Plan, with budget, and supporting documents, attached as **Appendix D.**
- c. To “Incur” costs means that the **SUBRECIPIENT** has obligated the Subaward Funds. FRF may be used only to cover costs incurred during the period beginning on March 3, 2021 and ending September 30, 2024.
- d. To “Obligate” funds means orders placed for property and

services, contracts and subawards made, and similar transactions during a given period that require payment by the **SUBRECIPIENT** during the same or a future period.

e. "Expend" is defined as when an expense is actually paid by the **SUBRECIPIENT**.

2. Applicability of Subrecipient Agreement and Provisions.

This Agreement, including all its Appendices, is intended to be the full and complete expression of, and shall constitute the entire agreement between the Parties. All prior and contemporaneous understandings, agreements, promises, representations, terms and conditions, whether oral or written, are superseded and replaced by this Agreement.

3. Authorized Representative and Administrative Oversight.

a. The **SUBRECIPIENT** shall work with the Department of Water Resources ("Administrative Oversight"), and its Authorized Representative with respect to this Agreement.

b. Each Party shall appoint an Authorized Representative who has the authority and requisite experience to manage all Agreement related matters. Notice of the appointed Authorized Representative shall be provided to each Party within five (5) calendar days of the execution of this Agreement. If either party changes its Authorized Representative or their scope of authority, they shall immediately notify the other Party pursuant to Article 12.

c. The Administrative Oversight shall serve as the administrative oversight of this Agreement including the **SUBRECIPIENT's** compliance with applicable federal and Navajo Nation laws, regulations, and policies; and financial reporting.

4. Agreement Number.

Contract number C-_____, as assigned by the Office of the Controller, shall cover this Agreement. Reference to this number shall be made on request for release of Subaward Funds submitted by the **SUBRECIPIENT** to the **NATION** for payment.

5. Effective Date and Period of Performance.

a. This Agreement is effective upon execution by all the **PARTIES**.

b. The period of performance shall begin on the Effective Date of this Agreement. The **SUBRECIPIENT** shall be required to incur costs, meaning to obligate funds by September 30, 2024, and expend funds by September 30, 2026 unless an earlier or later date is determined by the **NATION** through a resolution of the Navajo Nation Council or a Standing Committee of Council, and with written notice provided to the **SUBRECIPIENT**. The period of performance shall end upon the acceptance and approval by the Authorized Representative, the FRF Office, OMB, and OOC of the **SUBRECIPIENT's** final financial close out report and performance report.

6. Amount and Payment of Subaward.

a. The **NATION** agrees to allocate and disburse the Subaward Funds to the **SUBRECIPIENT** for purposes specified in the **Appendix A— Scope of Work** by paying a sum not to exceed \$1,146,748.00 ("Subaward Funds"), per **Appendix B – Budget**.

- b. Payments of the Subaward Funds shall be made in installments according to the Disbursement Schedule in **Appendix C** to this Agreement, which shall be subject to approval by the FRF Office in consultation with OOC and the Administrative Oversight. The **NATION** may withhold or delay disbursements if the **NATION** determines that the **SUBRECIPIENT** has failed to comply with its obligations under this Agreement. This determination shall be made by the FRF Office in consultation with OOC and the Administrative Oversight. The **SUBRECIPIENT** must provide documentation that it has obligated or expended 75% of its prior disbursement installment before OOC will release the next disbursement installment. If the **SUBRECIPIENT** expends 75% of its disbursement installment prior to the end of a twelve-month period, the **SUBRECIPIENT** may request to the FRF Office, the Administrative Oversight, and OOC that OOC release the next disbursement installment prior to the end of that twelve-month period.
- c. No payment of Subaward Funds shall be made unless and until approved by the FRF Office, the Administrative Oversight, and OOC. The **NATION's** approval of payments of Subaward Funds shall be based on the **SUBRECIPIENT's** actual costs and achievement of project milestones in accordance with the Disbursement Schedule. The **NATION** may request that the **SUBRECIPIENT** provide supporting documentation of actual costs, including but not limited to work orders, contracts, purchase orders, invoices, and receiving records.
- d. The **SUBRECIPIENT** shall work with the Accounts Payable Section of OOC to set up ACH (Automated Clearing House) electronic fund transfers, and shall provide OOC with an updated W-9 form on an annual basis.

7. Use and Return of Funds.

- a. FRF comprising the Subaward Funds, may only be used pursuant to Section 9901 of the ARPA and all the rules, regulations, and guidance implementing Section 9901 of the ARPA that are applicable to Tribal governments and their subrecipients. The use of FRF must also comply with all applicable Navajo Nation laws.
- b. The **SUBRECIPIENT** affirms and agrees that it shall only incur costs under the Subaward and expend Subaward Funds for the purposes outlined in **Appendix A – Scope of Work**.
- c. If any portion of Subaward Funds remain unexpended on September 30, 2026, unless an earlier or later date is determined by the **NATION** through a resolution of the Navajo Nation Council or a Standing Committee of Council, **SUBRECIPIENT** shall immediately return such portion of the Subaward Funds to the **NATION**. Upon the termination of this Agreement, the **SUBRECIPIENT** may be required to immediately return the unexpended portion of the Subaward Funds to the **NATION**.
- d. Where the **NATION** determines the **SUBRECIPIENT** expended Subaward Funds in violation of this Agreement or any applicable laws and regulations, the **SUBRECIPIENT** shall immediately return such portion of the Subaward Funds the **NATION** determined were improperly expended.
- e. If the **SUBRECIPIENT** fails to return such Subaward Funds to the **NATION** when due, the **SUBRECIPIENT** will incur a delinquent accounts receivable debt, due and owing to the

NATION. Further, the **NATION** may offset any future payments due to the **SUBRECIPIENT** by the amount owed, and may pursue all other available legal action against the **SUBRECIPIENT**.

8. Pre-Agreement Costs.

Costs incurred before the finalization of this Agreement that are within the scope of work of the Agreement and that the **NATION** deems reasonable, allowable, and allocable to performance of the Agreement may be paid under this Agreement. This determination shall be made by the FRF Office in consultation with the Administrative Oversight and OOC. All pre-Agreement costs shall be subject to the terms of this Agreement as if such Agreement were in effect when the costs were incurred.

9. Contingency Reserve.

If the scope of work of this Agreement involves construction, the **SUBRECIPIENT** may, but shall not be required to, include a portion of the Subaward as a contingency reserve to cover cost overruns due to the inflationary costs of building materials and labor or other construction contingencies. In the event of a cost overrun due to construction contingencies, the **SUBRECIPIENT** shall first exhaust its own internal funding sources, and then may notify the Authorized Representative and Administrative Oversight of its need to access funds from the Navajo Nation Construction Contingencies Expenditure Plan approved in section 13 of Council Resolution CJN-29-22 which are subject to an administrative approval process. If the contingency cannot be funded through the Construction Contingencies Expenditure Plan, the Administrative Oversight may choose to seek approval of a supplemental appropriation of funds through a resolution approved by the Navajo Nation Council.

10. Administrative Costs.

The **NATION** shall allow the **SUBRECIPIENT** to budget and expend two percent (2%) of the total Subaward for administrative costs. The **SUBRECIPIENT** may use funds for administering the **SUBRECIPIENT**'s FRF projects and programs under the approved Expenditure Plan, including costs of consultants to support effective management and oversight, including consultation for ensuring compliance with legal, regulatory, and other requirements. Further, costs must be reasonable and allocable as outlined in 2 CFR 200.404 and 2 CFR 200.405. The **SUBRECIPIENT** is permitted to charge both direct and indirect costs as administrative costs. If the total Subaward is not fully expended within the terms of the Agreement, the **SUBRECIPIENT** shall be required to immediately return to the **NATION** the remaining balance of the Subaward Funds, and an additional amount to include the 2% for administrative costs of the balance of the Subaward Funds, even if the **SUBRECIPIENT** fully expended the administration funds.

11. Availability of Funds.

The liability of the **NATION** under this Agreement is contingent upon the availability of funds pursuant to 2 N.N.C. §§ 223(A) and (B).

12. Contact Information; Notice.

Copies of all correspondence, reports, and notices under this Agreement shall be furnished to the Authorized Representative, with a copy to the FRF Office, OOC and Office of Management and Budget ("OMB") Contracts and Grants Section.

13. Reporting Requirements.

- a. The **SUBRECIPIENT** shall adhere to the following reporting requirements and provide the documentation requested on a monthly basis, unless specified otherwise, to the Administrative Oversight, with a copy to the FRF Office, OOC, and OMB, within ten (10) calendar days following the end of the month.
- b. The **NATION** requires the monthly reporting requirements listed below from the **SUBRECIPIENT**:
 - i. A detailed report that compares budgeted expenditures to actual expenditures for costs incurred;
 - ii. Completion of the OMB Program Performance Criteria Form;
 - iii. A narrative report providing monthly project assessment, including a summary of project activities, accomplishments with dates, impediments encountered, and impediments forecasted with planned responses;
 - iv. A listing of all property purchased with the Subaward Funds costing \$5,000 or more with an expected useful life of more than one year, such as buildings, vehicles, machinery, and equipment; and
 - v. Other data, records, information, and maps related to the progress of the project, that document changes made to the project since the previous monthly report.
- c. The FRF Office, in consultation with OOC and the Administrative Oversight performed a risk assessment on the **SUBRECIPIENT**. The **SUBRECIPIENT** was determined to be low risk. The risk assessment included consideration of such factors as: the **NATION**'s evaluation of the **SUPRECIPIENT**'s past performance in the context of other subawards, grants, contracts, or other transactions and business opportunities; the **SUBRECIPIENT**'s prior experience with similar subawards; the results of previous audits and whether the **SUBRECIPIENT** receives a Single Audit; whether the **SUBRECIPIENT** has new personnel or new or substantially changed systems; and the extent and results of federal funding agency monitoring. The **NATION** may repeat its risk assessment evaluation of the **SUBRECIPIENT** at any time during the term of this Agreement. Additional considerations may include the **SUBRECIPIENT**'s compliance or noncompliance with reporting requirements and other terms and conditions of this Agreement.
- d. Depending on the **NATION**'s assessment of risk posed by the **SUBRECIPIENT**, the **NATION** may impose additional monitoring tools to ensure the **SUBRECIPIENT**'s accountability and compliance with Subaward requirements and achievement of performance goals. This could include the **NATION**: providing the **SUBRECIPIENT** with training and technical assistance on program-related matters; performing on-site reviews of the **SUBRECIPIENT**'s program operations; and imposing additional reporting requirements and other compliance monitoring procedures.
- e. If the FRF Office, in consultation with OOC and the Administrative Oversight, determines that the **SUBRECIPIENT** poses a moderate or high risk for noncompliance with federal laws, regulations, and the terms and conditions of this Agreement the **NATION** may require the following additional reporting:
 - i. a detailed line-item expenditure report, with General Ledger detail, for the month reported;

- ii. supporting documentation for any individual expenditure greater than twenty-five thousand dollars (\$25,000) incurred during the month reported; and
 - iii. a reconciliation of the Subaward Funds, starting with the beginning balance, cash received, disbursements to date, program income (if applicable), and ending balance.
- f. The **SUBRECIPIENT** may be required to attend a training on the eligible uses of the Subaward Funds based on past experience with managing federal awards programs or on the **NATION'S** risk assessment of the **SUBRECIPIENT**.
- g. If the **SUBRECIPIENT** fails to timely submit such required reports or if the **SUBRECIPIENT'S** reports show lack of progress and/or low expenditure, it shall be in default under this Agreement. The **NATION** shall not disburse any Subaward Funds until the required reports are submitted.
- h. The **SUBRECIPIENT** shall submit a final financial closeout report providing a final accounting of the uses of the Subaward Funds, which should be supported by documentation, including but not limited to receipts, invoices, contracts, listing of all property purchased with the Subaward Funds costing \$5,000 or more with an expected useful life of more than one year, and payroll records. This final report must be submitted the earlier of forty-five (45) days after September 30, 2026 unless an earlier or later date is determined by the **NATION** through a resolution of the Navajo Nation Council or a Standing Committee of Council or thirty (30) days after the completion of all projects within the scope of work of this Agreement. If, however, this Agreement is terminated, the final financial closeout report is due thirty (30) days after termination of the Agreement. If the Subaward Funds are being disbursed on a reimbursement basis according to the disbursement schedule attached as Appendix C, the **NATION** shall not release the final disbursement of Subaward Funds until the final financial closeout report is submitted to Administrative Oversight, the FRF Office, OOC, and OMB, and is reviewed and approved by OOC. If the **SUBRECIPIENT** fails to timely submit a final financial closeout report, it shall be in default on this Agreement and shall return the Subaward Funds in full to the **NATION** within fifteen (15) days following the reporting deadline. The **SUBRECIPIENT** shall be required to return these Subaward Funds without first receiving Notices of Default or Termination from the **NATION**.
- i. The **SUBRECIPIENT** shall keep detailed and accurate records of all expenditures and receipts related to this Agreement, and shall provide the **NATION** with any reporting summarizing actual expenditures, as requested by the FRF Office, OOC, or the Administrative Oversight, including but not limited to:
 - i. Inventory listing of all property purchased with the Subaward Funds costing \$5,000 or more with an expected useful life of more than one year;
 - ii. Documentation that the costs incurred were fair and reasonable;
 - iii. Payroll records;
 - iv. General ledger;
 - v. Cash disbursements journal;
 - vi. Contracts and purchase orders with contractors and vendors;
 - vii. Vendor invoices;
 - viii. Expenditure reports; and

ix. Debt agreements.

j. The **SUBRECIPIENT** shall also assist the Administrative Oversight to prepare and present quarterly reports to its legislative oversight committee of the Navajo Nation Council in accordance with the requirement in Section 15 of CJN-29-22.

k. All financial reporting and record keeping requirements shall survive the expiration and termination of this Agreement.

14. Single Audit.

a. The Single Audit Act applies to the expenditure of the Navajo Nation Fiscal Recovery Funds. **SUBRECIPIENT** shall have a Single Audit performed by an independent external auditor if it expends Seven Hundred and Fifty Thousand (\$750,00) or more dollars of federal funds in one fiscal year.

b. **SUBRECIPIENT** can use the two percent (2%) administrative cost allocated in Section 10 of this Agreement to pay for the Single Audit.

15. The Nation's Right to Inspect Places of Business and to Inspect and Audit Books and Records.

a. The **SUBRECIPIENT** agrees that the **NATION** may, at reasonable times, inspect the part of the plant or place of business and the project worksites of the **SUBRECIPIENT** that are related to the performance of this Agreement; and the **SUBRECIPIENT** further agrees that the **NATION** and its auditors, may at reasonable times and places, inspect and audit the **SUBRECIPIENT** books and records to the extent that such books and records relate to the performance of this Agreement. The **SUBRECIPIENT** shall maintain such books and records, and such books and records of any Subcontractor, for at least five (5) years after all Subaward Funds have been expended by the **SUBRECIPIENT** or returned to the **NATION**, or from the date of final payment under this Agreement, whichever is later.

b. Further, the **SUBRECIPIENT** agrees to include in any Subcontractor agreement related to this Agreement, provisions that the Subcontractor agrees (i) that the **NATION** may, at reasonable times, inspect the part of the plant or place of business of the Subcontractor that is related to the performance of this Agreement; (ii) that the **NATION** may, at reasonable times and places, inspect and audit the Subcontractor's books and records to the extent that such books and records relate to the performance of this Agreement; and (iii) that the Subcontractor shall maintain its books and records related to the performance of this Agreement for at least five (5) years from the date of the **SUBRECIPIENT** final payment under this Agreement.

16. Reserved.

17. Evaluation and On-Site Inspection.

a. Progress Inspections. The Administrative Oversight and the FRF Office will conduct periodic on-site monitoring to ensure efficient completion of the work.

b. Final Inspections. Within ten (10) calendar days after completion of the project, the

SUBRECIPIENT shall notify the Administrative Oversight and the FRF Office, in writing, of completion of the work. The **SUBRECIPIENT** and the Administrative Oversight and the FRF Office shall perform a final inspection no later than fifteen (15) days from the date the Administrative Oversight and the FRF Office receive the completion notice.

18. Assignment.

- a. The **SUBRECIPIENT** shall not assign or otherwise transfer its rights, nor delegate any of its obligations, under this Agreement without prior written approval from the **NATION**. This Agreement is for the exclusive benefit of the **SUBRECIPIENT** and the **NATION**, and not for the benefit of any third party, including without limitation, any owner, partner, board member, employee, or volunteer of the **SUBRECIPIENT**.
- b. The **SUBRECIPIENT** shall not use Subaward Funds to grant subawards to other entities.
- c. The **SUBRECIPIENT** shall not pledge nor otherwise assign any monies due under this Agreement or any claim arising thereunder, to any party or parties, bank, trust company or other financial institutions.
- d. The **SUBRECIPIENT** shall immediately provide written notification to the **NATION** of any changes in the **SUBRECIPIENT'S** size or structure that would affect the **SUBRECIPIENT'S** eligibility for or ability to manage the Subaward Funds; any circumstances preventing expenditure of Subaward Funds by the **SUBRECIPIENT** for the purposes described in this Agreement; or any expenditure using Subaward Funds made for any purpose other than those for which the Agreement is intended.

19. False Statements by Subrecipient.

By acceptance of this Agreement, the **SUBRECIPIENT** makes all the statements, representations, warranties, guarantees, certifications, and affirmations contained herein. If any of the statements, representations, warranties, guarantees, certifications, and affirmations are false or if the **SUBRECIPIENT** in any other way executes the Agreement including false statements, or it is subsequently determined that the **SUBRECIPIENT** has violated any of the statements, representations, warranties, guarantees, certifications, or affirmations included in this Agreement, the **NATION** may consider such an act a default under this Agreement and may terminate or void this Agreement for cause and pursue other remedies available to the **NATION** under this Agreement and all applicable laws.

20. Conflicts of Interest.

- a. Each **PARTY** warrants that there was no improper influence involved in the granting of the Subaward to the **SUBRECIPIENT**, and each **PARTY** further warrants that it did not and will not employ, retain, or contract with any person or entity on a contingent compensation basis for the purpose of seeking, obtaining, maintaining, or extending this Agreement. Each **PARTY** agrees, warrants, and represents that no gratuity whatsoever has been or will be offered or conferred with a view towards obtaining, maintaining, or extending this Agreement.
- b. The officials and employees of the **PARTIES** shall not have any personal economic interest or special interest, direct or indirect, which gives rise to a conflict of interest or

would otherwise violate the Navajo Nation Ethics in Government Law, 2 N.N.C. §§3741 *et. seq.*, with respect to this Agreement. The **SUBRECIPIENT** shall disclose in writing to the **NATION** any potential conflict of interest, as defined in the Ethics in Government Law, affecting the Subaward Funds. The **NATION** will review all disclosed potential conflicts of interest and may terminate this Agreement according to Article 28 of this Agreement.

- c. The **SUBRECIPIENT** understands and agrees it will maintain a conflict of interest policy consistent with 2 C.F.R. § 200.318(c) and that such policy is applicable to each activity funded under this Subaward. The **SUBRECIPIENT** shall disclose in writing to the **NATION** any potential conflict of interest affecting the Subaward Funds in accordance with 2 C.F.R. § 200.112. The **SUBRECIPIENT** will establish safeguards to prohibit its officers, agents, employees, and members from using their positions for a purpose that constitutes or presents the appearance of personal or organizational conflict of interest, self-dealing, or personal gain, whether for themselves or others, particularly those with whom they have family, business, or other ties. The **SUBRECIPIENT** will operate with complete independence and objectivity without potential, actual, or apparent conflict of interest with respect to its performance under this Agreement.

21. Fraud, Waste, and Abuse.

- a. The **SUBRECIPIENT** understands that the **NATION** will not tolerate any type of fraud, waste, abuse, or misuse (“misuse”) of Subaward Funds received from the **NATION**. The **SUBRECIPIENT** understands and agrees that misuse of Subaward Funds shall be considered an act of default under this Agreement as grounds for the **NATION** to terminate this Agreement, and may further result in a range of penalties, including suspension of current and future funds; ineligibility for, suspension, or debarment from Navajo Nation contract opportunities; recoupment and offset of monies provided under an award; and civil and/or criminal penalties. In the event the **SUBRECIPIENT** becomes aware of any allegation or a finding of fraud, waste, or misuse of funds received from the **NATION** or made against the **SUBRECIPIENT**, the **SUBRECIPIENT** shall immediately notify the **NATION** of said allegation or finding and continue to inform the **NATION** of the status of any on-going investigations into the allegations or steps being taken to remedy the finding.
- b. In accordance with 41 U.S.C. § 4712, the **SUBRECIPIENT** shall provide protections for whistleblowers. The **SUBRECIPIENT** shall not discharge, demote, or discriminate against an employee in reprisal for disclosing to the **SUBRECIPIENT**, the **NATION**, or relevant federal authorities, evidence of gross mismanagement or waste of the Subaward, an abuse of authority relating to the Subaward, a substantial and specific danger to public health or safety, or a violation of law, rule, or regulation related to the Subaward.

22. Taxes.

The **SUBRECIPIENT** shall comply with all applicable Navajo Nation tax laws under Title 24 of the Navajo Nation Code and corresponding regulations as amended from time to time. The **SUBRECIPIENT’S** contractor is subject to and shall be liable for payment of the Navajo Nation Sales Tax, at the prevailing rate, on gross receipts for all work performed within the territorial jurisdiction of the Navajo Nation pursuant to 24 N.N.C. § 601 *et seq.*, and the Navajo Nation Sales Tax Regulations § 6.101 *et seq.*, as amended from time to time, except that work performed within the To’Nanees’Dizi Local Government (“Tuba City Chapter”) or the Kayenta Township is subject to

their respective local sales taxes as amended from time to time. In addition to being subject to Navajo Nation Sales Tax, the **SUBRECIPIENT'S** contractor is subject to local sales tax on gross receipts for all work performed within a governance-certified chapter that imposes a local sales tax pursuant to a duly enacted local tax ordinance and the Uniform Local Tax Code, 24 N.N.C. § 150 *et seq.* The **SUBRECIPIENT'S** contractor is solely responsible for the payment of all applicable taxes related to this Agreement, and the **NATION** is not responsible for withholding or paying any income taxes, Federal Insurance Contributions Act (FICA) taxes, unemployment taxes, or any other taxes, from any payments owed to the **SUBRECIPIENT'S** contractor, nor shall the **NATION** be responsible for remitting the **SUBRECIPIENT'S** contractor share of employment taxes to the federal or any state governments.

23. Insurance Coverage.

The **SUBRECIPIENT** shall obtain and maintain adequate insurance coverage as recommended and verified by the Navajo Nation Risk Management Program ("RMP"). The **SUBRECIPIENT** shall provide its Verification of Insurance indicating they are in good standing with the Nation's insurance. The **SUBRECIPIENT** shall notify the Administrative Oversight, the FRF Office and the RMP, c/o The Navajo Nation, P.O. Box 1690, Window Rock, Arizona 86515 within five (5) days of any change in the insurance policy. Failure to fully comply with this provision shall render this Agreement voidable by the **NATION** discretion.

24. Modifications.

- a. The **NATION** and the **SUBRECIPIENT** may agree to modify the Agreement. Such modifications include, but are not limited to, modifying the Scope of Work, adding funds to previously un-awarded cost items or categories, changing funds in any awarded cost item or category, de-obligating awarded funds, or changing the **SUBRECIPIENT'S** Authorized Representative. The terms of any such modifications must be made in writing, and must be signed by both the **SUBRECIPIENT** and the **NATION** to take effect.
- b. Modifications must adhere to the requirements of Council Resolution CJN-29-22 and the Fiscal Recovery Fund Procedures set forth in the Budget and Finance Committee Resolution BFS-31-21. All modifications shall require review by the Department of Justice ("DOJ") for an initial eligibility determination and a determination of whether legislative approval of the modification is required. Certain modifications may require approval by the Navajo Nation Council or Committees of Council. For any modification that includes a modification of the Project's budget, a Budget Revision Request form, shall be completed by the **SUBRECIPIENT** and submitted first to the Authorized Representative and the FRF Office for review and then forwarded to DOJ for review and the OMB for approval.

25. Remedies for Non-Compliance.

- a. If the **NATION** determines that the **SUBRECIPIENT** materially fails to comply with any term of this Agreement, whether stated in a federal or Navajo Nation statute, regulation, an assurance, legislation, a notice of award, or any other applicable requirement, the **NATION** will issue a Notice of Failure to Comply, of Suspension, or of Termination, and may take action, in its sole discretion, including but not limited to:
 - i. Changing the **NATION's** risk assessment of the **SUBRECIPIENT** and requiring additional and more stringent reporting from the **SUBRECIPIENT**;

- ii. Placing liens on the **SUBRECIPIENT's** assets purchased with the Subaward Funds;
- iii. Temporarily withholding disbursements of Subaward Funds pending correction of the deficiency;
- iv. Disallowing or denying use of Subaward Funds for all or part of the cost of the activity or action not in compliance;
- v. Disallowing claims for reimbursement;
- vi. Wholly or partially suspending this Agreement;
- vii. Requiring return of previous disbursements of Subaward Funds;
- viii. Prohibiting the **SUBRECIPIENT** from applying for or receiving additional funds for other programs administered by the Navajo Nation until repayment to the **NATION** is made and any other compliance or audit finding is satisfactorily resolved;
- ix. Reducing the amount of the Subaward from the **NATION**;
- x. Imposing a Corrective Action Plan;
- xi. Withholding disbursements of future awards from the **NATION**, and deeming the **SUBRECIPIENT** to be ineligible for future business opportunities with the **NATION**, including but not limited to: awards; contracts; grants; leases; rights of way; licenses; loans, permits;
- xii. Offsetting future awards and payments to the **SUBRECIPIENT**;
- xiii. Terminating this Agreement; or
- xiv. Taking other enforcement action or remedies, including imposing sanctions without first requiring a Corrective Action Plan, or pursuing other legal remedies.

b. The **SUBRECIPIENT'S** costs resulting from obligations incurred during a suspension or after termination of this Agreement will not be allowable unless the **NATION** expressly authorizes such costs in the Notice of Failure to Comply, of Suspension, or of Termination. Absent such express authorization, the **SUBRECIPIENT** shall return that portion of the Subaward Funds to the **NATION**.

26. Non-Waiver.

No failure on the part of the **NATION** to act, and no delay in exercising any right hereunder shall operate as a waiver thereof; nor shall any single or partial act or exercise by the **NATION** of any right hereunder preclude any other or further exercise thereof or the exercise of any other right. The remedies herein provided are cumulative and not exclusive of any remedy available to the **NATION** at law or in equity.

27. Expiration or Termination of the Agreement.

a. The **NATION** may, at its sole discretion, terminate this Agreement for cause or convenience, without recourse, liability, or penalty against the **NATION**, upon Written Notice to the **SUBRECIPIENT**, without further notice to or opportunity to cure by the **SUBRECIPIENT**. Such notification of termination will be effective on the date of the notification, if no other effective date is specified in the Notice of Termination;

b. The **NATION** and the **SUBRECIPIENT** may mutually agree to terminate this Agreement. The **NATION** in its sole discretion will determine if, as part of the agreed termination, the **SUBRECIPIENT** is required to return any or all of the disbursed Subaward Funds within ten

(10) business days of termination. This determination and its terms shall be communicated in writing to the **SUBRECIPIENT**;

- c. Termination is not an exclusive remedy for the **NATION**, but will be in addition to any other rights and remedies provided in equity, at law, or under this Agreement. Following termination by the **NATION**, the **SUBRECIPIENT** shall continue to be obligated to the **NATION** for an accounting of and the return of Subaward Funds in accordance with applicable provisions of this Agreement. In the event of termination under this Section, the **NATION**'s obligation to reimburse the **SUBRECIPIENT** is limited to allowable costs incurred and paid by the **SUBRECIPIENT** prior to the effective date of termination, and any costs determined by the **NATION** in its sole discretion to be allowable, reasonable, and necessary for cost-effective wind up of the allocation.
- d. Termination of this Agreement for any reason, or expiration of this Agreement shall not release the **PARTIES** from any liability or obligation set forth in this Agreement that is expressly stated to survive any such termination or expiration. The rights and obligations pertaining to the allocation, close-out, cooperation, and provision of additional information, return of funds, audit rights, records retention, public information, and any other provision implying survivability shall remain in effect after the expiration or termination of this Agreement.

28. Disputes.

Any and all disputes arising under, related to, or in connection with this Agreement shall be resolved first through informal, good faith negotiation between the **PARTIES** under the laws of the Navajo Nation. The **PARTIES** shall use their best faith efforts to resolve any dispute informally and expeditiously through such negotiations at the staff level. Each **PARTY** shall designate a staff person to meet with the other **PARTY** at a mutually agreeable time and place. The **PARTIES** will honor all reasonable requests for relevant documents and information. If the dispute cannot be resolved within fifteen (15) business days, the **PARTIES** shall refer the matter to the Executive Director of DCD and the Chapter President, and shall consult with the Department of Justice, to assist with interpretation of this Agreement and applicable Navajo Nation laws and policies. If the **PARTIES** are unable to resolve the dispute, the **NATION** shall terminate this Agreement after consultation with the DOJ. The **SUBRECIPIENT** shall return any Grant Project Funds that are not Spent or Encumbered to the **NATION** pursuant to Section 7 of this Agreement.

29. Applicable Law and Jurisdiction.

- a. The **SUBRECIPIENT** shall comply with all Navajo Nation laws. Failure to comply with Navajo Nation law shall be an act of default, and grounds for termination of this Agreement by the **NATION**. The **SUBRECIPIENT** agrees to be subject to the jurisdiction of Navajo Nation courts and tribunals.
- b. This Agreement will be governed in all respects by the laws of the **NATION**, both as to interpretation and performance, without regard to conflicts of law or choice of law provisions. Any action arising out of or in connection with this Agreement may only be instituted and maintained in a Navajo Nation court.

30. Force Majeure.

Neither the **SUBRECIPIENT**, nor the **NATION** shall be required to perform any obligation under

this Agreement or be liable or responsible for any loss or damage resulting from its failure to perform so long as performance is delayed by force majeure or acts of God, including but not limited to strikes, lockouts or labor shortages, embargo, riot, war, revolution, terrorism, rebellion, insurrection, flood, or natural disaster. For the purposes of this Agreement, COVID-19 shall not be considered a force majeure. The **SUBRECIPIENT** must inform the **NATION** of any force majeure events delaying performance of its obligations in writing, with proof of receipt of notice, within three (3) business days of the commencement of such force majeure or acts of God, or will otherwise waive this right as a defense.

31. No Obligation by Federal Government.

The **PARTIES** acknowledge and agree that the federal government is not a Party to this Agreement and is not subject to any obligations or liabilities to either Party, any third Party, or any subcontractor pertaining to any matter related to this Agreement.

32. Compliance with Federal Laws, Regulations, and Executive Orders.

- a. The **SUBRECIPIENT** will comply with all applicable federal laws, regulations, executive orders, policies, procedures, and directives, which may include but shall not be limited to: the Uniform Administrative Requirements, Cost Principles, and Audit Requirements for Federal Awards, 2 C.F.R. Part 200; Procurement Standards in 2 C.F.R. Part 200 Subpart D; and applicable legal requirements cited in 2 C.F.R. Part 200 Appendix II and the **NATION's** Financial Assistance Agreement with Treasury attached as Appendix F.
- b. The **SUBRECIPIENT** shall comply with all federal requirements in the ARPA; the Financial Assistance Agreement between Treasury and the **NATION**, identified as Appendix F; the CSLFRF Final Rule and other Treasury guidance in the form of Frequently Asked Questions; and the CSLFRF Compliance and Reporting Guidance, identified as Appendix G.
- c. For capital projects and infrastructure projects in excess of \$10 million, the **SUBRECIPIENT** will need to provide documentation of compliance with applicable wage and labor standards.
- d. Any publications produced with funds from this Subaward must display the following language: "This project [is being] [was] supported, in whole or in part, by federal award number 21.027 awarded to the Navajo Nation by the U.S. Department of the Treasury."

33. Certification Regarding Lobbying (2 CFR 200.450).

By signing this Agreement, the Authorized Representative certifies, to the best of his/her knowledge and belief, that no federally appropriated funds have been or will be paid, by or on behalf of the **SUBRECIPIENT**, to any person or entity for influencing or attempting to influence an officer or employee of any agency, a Member of Congress, an officer or employee of Congress, or an employee of a Member of Congress in connection with the awarding of any federal contract, the making of any federal grant, the making of any federal loan, the entering into of any cooperative agreement, and the extension, continuation, renewal, amendment, or modification of any federal contract, grant, loan, or cooperative agreement in accordance with 2 CFR 200.450. If any funds other than federally appropriated funds have been paid or will be paid to any person or entity for influencing or intending to influence an officer or employee of any agency, a Member of Congress, an officer or employee of Congress, or an employee of a Member of Congress in connection with this federal contract, grant, loan, or cooperative agreement, the **SUBRECIPIENT**

shall complete and submit Standard Form-LLL, Disclosure Form to Report Lobbying, to the NATION. This certification is a material representation of fact upon which reliance was placed when this transaction was made or entered into. Submission of this certification is a prerequisite for making or entering into this transaction imposed by 31 U.S.C. § 1352. Any person who fails to file the required certification shall be subject to a civil penalty of not less than \$10,000 and not more than \$100,000 for each such failure.

34. No Agency or Employment Relationship.

In its performance of work pursuant to this Agreement, the SUBRECIPIENT, unless it is a Navajo Nation Chapter or Township, shall be an independent entity from the NATION. The SUBRECIPIENT shall not be considered an employee or agent of the NATION. Nothing in this Agreement shall be construed to create any agency or employment relationship between the SUBRECIPIENT or any of its employees and the NATION. Neither Party shall have any right, power, or authority to assume, create, or incur any expense, liability, or obligation, whether express or implied, on behalf of the other Party. Nothing in this Agreement shall be construed to create any agency or employment relation between the PARTIES, and the SUBRECIPIENT is free to make its services available to third parties. The SUBRECIPIENT is not eligible to participate in, nor eligible for coverage under, any NATION employee benefit plan or offering.

35. Indemnification.

Except where the SUBRECIPIENT is another Navajo Nation Governmental Entity, such as a Chapter or Township, the SUBRECIPIENT agrees to hold harmless and indemnify the NATION against any and all losses, costs, damages, claims, accident or injury to person or property including death, attorneys' fees, expenses, and other liability whatsoever (collectively, "Claims"), arising under, related to, or in connection with this Agreement, except to the extent such Claims are directly caused by the gross negligence or wanton and willful conduct of the NATION or to the extent they result from the negligence of NATION officials or employees as provided for and in accordance with 1 N.N.C. § 551 *et seq.*

36. Rights of Other Parties.

Nothing in this Agreement shall be interpreted to create any rights in any third party that is not an entity or subdivision of the Navajo Nation government.

37. Conflicting and Additional Terms.

All additional terms and conditions of the SUBRECIPIENT are attached hereto and incorporated into this Agreement, provided however that in the event of any conflict between these Terms and Conditions and any additional terms

and conditions not attached to this Agreement shall have no force or effect.

38. Severability.

If any provision of this Agreement is held invalid by the Courts of the NATION, all remaining provisions which can be implemented shall remain in force and be given full force and effect.

///

IN WITNESS WHEREOF, we the undersigned hereby execute this Agreement:

For the SUBRECIPIENT:

For THE NAVAJO NATION:

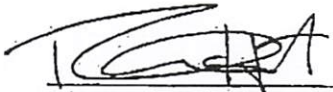

Chapter President
Naschitti Community Governance
Drawer D, Sheepsprings, NM 87364

9-5-23
Date



Buu Nygren, President
The Navajo Nation
Window Rock, AZ 86515

OCT 23 2023
Date

B 12/12/23

Appendix A

SCOPE OF WORK

NASCHITTI COMMUNITY GOVERNANCE SCOPE OF WORK

NASCHITTI BATHROOM ADDITION

This project will consist of allocating funds in the amount of 551,748.70 for Contractual Services to hire a contractor to build fifteen (15) bathroom additions for Naschitti community members. These bathroom additions will meet the needs of community members to allow for water and wastewater connections with the assistance of OEH, IHS and NTUA according to current building codes.

The project is located in Naschitti, NM area. The contractor shall provide all labor, materials, tools, equipment, supervision and other related items required to complete the project as required. The plans provide different options for the bathroom orientation, foundation type and roofing type. Each home will be assessed by the contractor to make any field adjustments as necessary as to how to build a complete and functional bathroom addition. The Project will include Site work, Building Pads and Foundations, Framing, Floor and Roofing, Mechanical, Plumbing and Electrical Work, installation of new fixtures and appliances in compliance with The NTUA and NECA Specifications. (See plans for additional and clarification information) All work shall be inspected and reported to Owner (Naschitti Community Governance).

- A. Explore and adapt the plumbing position.
- B. Explore and make modifications on the electrical installation.
- C. Delivery and installation of the new bathroom fixtures and appliances.
- D. Install vanity and sink.
- E. Install walk-in shower.
- F. New drop ceiling.
- G. Install new toilet.
- H. Install new towel Dryer-Radiator.

NASCHITTI HOUSE WIRING PROJECT:

This project will consist of allocating funds in the amount of \$525,000.00 for Contractual Services for certified Electricians to install/upgrade house wiring according to Navajo Nation/NTUA code to obtain certified affidavits for electrical hook up. Allocated funds will also include purchasing of electrical materials and supplies as needed.

The project is located in Naschitti, NM area. Currently this project will consist of two groups, Group A will have 30 homes and Group B will have 10 alternate homes if funds are still available. A Mandatory site visit is required at each project location. Each home will be assessed by the contractor to make any field adjustments as necessary as to how to complete conduit electrical system. These homes consist of new wiring, upgrades, and conversions from solar to hard lines. The contractor shall provide all labor, materials, tools, equipment, supervision and other related items required to complete the project. Contractor will provide and *install* all *electrical work* including, but not limited to, weather heads, drop loop. Meter/Panel boxes, wiring, circuit breakers, all switch gear, service *conduit*, outlets, receptacles, fittings, plates, lights. The cutting, threading, bending of all conduit by hand or machine and installation of such conduit. The homes may differ in structure at each location. All work shall be inspected and reported to Owner (Naschitti Community Governance) upon completion.

NASCHITTI RURAL ADDRESSING PROJECT:

This project will consist of allocating funds in the amount of \$70,000.00 to purchase signage materials to implement the local community Rural Addressing System and to hire two individuals to install signage and home identifier tags for the Rural Addressing Systems. This system will be a service to the Naschitti community as a whole as it will provide addressing for all homes located within Naschitti boundaries to access the E911 systems and home location identifiers for first responders for emergency situations.

The project is located in Naschitti, NM area. The contractor shall provide all labor, materials, tools, equipment, supervision and other related items required to complete the project as required.

Material will include but not limited to: 30 Shield Sign Intersection Sign Combo, 40 Cross Intersection, 450 Structure Identification Signage (w/Non-Flexible delineator post), and 1,000 Flexible Delineators.

NAVAJO NATION BATHROOM ADDITIONS

NAVAJO ENGINEERING AND CONSTRUCTION AUTHORITY
CONSTRUCTION DOCUMENTS
NAVAJO NATION

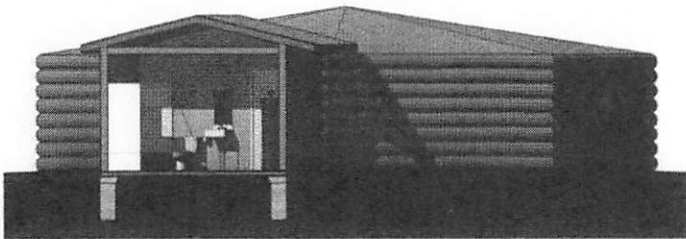
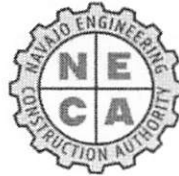

PROJECT TEAM

ARCHITECT
INDIGENOUS DESIGN STUDIO + ARCHITECTURE, LLC
8008 PENNSYLVANIA CIRCLE NE
ALBUQUERQUE, NM 87110
PH: 505.226.2565
CONTACT: TAMARAH BEGAY

STRUCTURAL ENGINEER
LUCCHINI TRUJILLO STRUCTURAL ENGINEER, INC.
4115 WOLCOTT AVE NE STE. G, ALBUQUERQUE, NM
87106
CONTACT: ANTONIO LUCCHINI

**MECHANICAL, ELECTRICAL AND PLUMBING
ENGINEERING**
1406 ORTIZ DR SE, ALBUQUERQUE NM 87108
CONTACT: NERISSA MUJIS

DRAWING INDEX

STRUCTURAL
S001 - OUTLINE SPECIFICATIONS S101-FOUNDATIONS
S102 - FLOOR FRAMING, ROOF FRAMING
S201 - FOUNDATION DETAILS
S301 - FRAMING DETAILS
S302 - FRAMING DETAILS

ARCHITECTURAL
A101 - FLOOR, ROOF PLANS & SCHEDULES
A102 - SECTIONS AND ELEVATIONS
A103 - ROOF AND FOUNDATION DETAILS

MECHANICAL, ELECTRICAL & PLUMBING
MEP - 001 OUTLINE SPECIFICATIONS & PROJECT NOTES
M101 - MECHANICAL FLOOR PLAN
E101 - ELECTRICAL FLOOR PLAN
E001 - ELECTRICAL SCHEDULES & ONELINE DIAGRAM
P101 - PLUMBING PLANS
MP001 - EQUIPMENT SCHEDULES & DETAILS

NAVAJO NATION BATHROOM ADDITIONS

NAVAJO NATION
CONSTRUCTION DOCUMENTS

OWNER:
NAVAJO ENG & CONSTRUCTION AUTHORITY

INDIGENOUS DESIGN STUDIO +
ARCHITECTURE, LLC



8008 Pennsylvania Cir NE
Albuquerque, NM 87110
Tel: 505.226.2565
Fax: 505.226.2566

ARCHITECT

MARK	DATE	DESCRIPTION
	Issue Date	

PROJECT NUMBER: MD-36
DRAWING FILE:
DRAWN BY: Author
CHECKED BY: Checker
COPYRIGHT 2020 Indigenous Design Studio + Architecture, LLC

SHEET TITLE
COVER SHEET

SHEET NUMBER

G-001

Sequence of

STRUCTURAL OUTLINE SPECIFICATIONS FOR NECA 150 BATHROOM ADDITIONS, SANTA FE, NM

I. DESIGN CRITERIA & GENERAL NOTES

- A. Design Codes and Materials:
 1. 2015 International Building Code (IBC)
 2. ASCE 7-10, Minimum Design Loads for Buildings and Other Structures
 3. ACI 318-14, Building Code Requirements for Reinforced Concrete
 4. American Wood Council, National Design Specification for Wood Construction 2015

B. VERTICAL DESIGN LOADS:

1. Live Loads
 - a) Floor _____ 40 PSF
 - b) Live Roof Loads _____ 20 PSF
2. Dead Loads
 - (1) Unfinished Live Load, L_u _____ 20 PSF
 - (2) Risk Category _____ II
3. Snow Loads
 - a) Roof Snow Load _____ 20 PSF
 - (1) Ground Snow Load, p_g _____ 20 PSF
 - (2) Risk Category _____ II
4. Wind Loads
 - a) Roof _____ 25 PSF
 - b) Floor _____ 25 PSF

C. HORIZONTAL DESIGN LOADS:

1. Wind Loads
 - a) Wind Category _____ II
 - b) Exposure _____ II
 - c) Ultimate Design Wind Speed $V = 0.60 \text{ GC}_{MC} \text{ GC}_{DT} - 115 \text{ MPH}$
 - d) Design Wind Pressures for Components and Cladding:
 - (1) Roof:
 - (a) Zone 1, $p = -28.8 \text{ psf / na}$
 - (b) Zone 2, $p = -60.0 \text{ psf / na}$
 - (c) Zone 3, $p = -82.0 \text{ psf / na}$
 - (2) Roof Overhangs:
 - (a) Zone 2, $p = -41.8 \text{ psf}$
 - (b) Zone 3, $p = -63.3 \text{ psf}$
 - (3) Walls:
 - (a) Zone 4, $p = -28.4 \text{ psf / } +28.4 \text{ psf}$
 - (b) Zone 5, $p = -48.4 \text{ psf / } +28.4 \text{ psf}$
 - (4) Exterior Wind Area = 10 sf

D. GENERAL NOTES

1. Drawings
 - a) Do not scale drawings.
 - b) See architectural, mechanical, electrical and plumbing drawings for exact location and arrangement of any pipes, support hangers, etc. required for mechanical and electrical equipment and not with other trades concerning plates, anchors, nails, etc. to be placed in concrete.
 - c) Any conflict between the structural drawings and specifications, and/or other discipline plans and/or specifications shall be brought to the attention of the architect prior to proceeding with the work.
2. Contractor shall verify all edge forms existing dimensions as well as the location of elevation changes, offsets, bolt heights, and tie-backs with other disciplines and notify the architect of any discrepancies that may exist prior to commencing construction.
3. OPENINGS
 - a) Openings, sleeves, etc. to be placed through any structural member shall first be approved by the structural engineer. Sleeves shall be provided for openings prior to placing of concrete. Cutting of hardened concrete shall not be permitted except by special structural approval which will be on an individual basis.
4. EXISTING STRUCTURES
 - a) Contract documents have been prepared using available drawings and site observations as permitted by access restrictions during design.
 - b) During construction, the contractor may encounter existing conditions which are not shown on any drawings or project documentation. Contractor shall notify the architect of all conditions not per the contract documents, including but not limited to:
 - (1) Sizes and dimensions other than those shown.
 - (2) Material or construction to materials and components.
 - (3) Conditions of accessibility or lack of support.
 - (4) Items noted as existing on the drawings, but not found in the field.
 - c) Prepare dimensional drawings of all discovered items.
 - d) Contractor shall hold verify all existing structural conditions prior to submitting shop drawings.
 - e) Submit a dimensional drawing of all new openings through existing structure and secure approval prior to cutting. Drawing shall show vertical and horizontal location and size of proposed opening(s).
 - f) The contractor shall provide all measures necessary to protect the structure during construction. Such measures shall include, but not be limited to bracing and shoring for loads due to hydrostatic, earth, wind or seismic forces, construction equipment, etc. Observation notes to be filed by the structural engineer shall not include inspection of the above items.
 - g) Cost of additional field and office work necessitated by requests by the contractor for an option of time to install or materials in construction shall be borne by the contractor. Options for cost overruns, however, shall be the responsibility for all changes necessary if the choices an option and the cost associated with it.
5. Foundation Notes
 - a) Geotechnical engineering study and recommendations for this project have not been performed. Design to be based on the assumed values below. A geotechnical study shall be completed for each site prior to construction for the verification of all soil design values and for verification of the applicability of the foundation system shown.
 - b) Important additional information concerning specific soil conditions is contained in this report and shall be reviewed prior to the start of construction.
 - c) Design to be based on recommendations provided by the geotechnical engineering study:
 - (1) Allowable Soil Bearing Pressure = 1200 psf
 - (2) Frost Depth / Minimum Exterior Footing Embedment = 2'-0"
 - (3) Building pad shall be over-excavated a minimum of 2'-0" below bottom of footing and

excavated with engineered fill. Excavation shall extend laterally 2'-0" beyond building perimeter.

4) Requirements for granular base and capillary (paper) barriers is specified in this report. Areas where the capillary barriers are required shall be coordinated with the architect prior to construction. The barrier shall have a minimum thickness of 10 mils and shall conform to the requirements of ACI 308.1R-04.

c) Contractor shall be responsible for providing positive water drainage away from structures, during and after construction.

(1) It is important to understand that the performance of the foundation is linked directly to the consistency of the moisture content in the soil. The geotechnical engineering study provides recommendations for natural ground preparation, remedial earthwork, dewatering, grading, and landscaping.

2. When a geotechnical engineering study is not obtained the owner must either obtain a geotechnical study or provide that even with proper compaction of native soils listed in above below, will not ensure differential settlement is mitigated. Suggested site preparation on the structural drawings does not ensure differential settlement is mitigated. Typical geotechnical studies contain specific recommendations concerning clearing and grubbing, site, exterior and bearing surface preparation, structural fill requirements, compaction requirements, and drainage and sloping requirements not necessarily shown on these drawings. Refer to structural recommendations for suggested site prep and consult a geotechnical engineer as required.

a) The contractor shall engage and bear the cost of a geotechnical engineer or designated representative to monitor site preparation, foundation construction and retaining wall construction. The geotechnical engineer shall provide continuous on-site observations by expedient personnel during construction of corrected earthwork. Refer to structural recommendations for suggested site prep and consult a geotechnical engineer as required.

b) The contractor shall engage and bear the cost of a geotechnical engineer or designated representative to monitor site preparation, foundation construction and retaining wall construction. The geotechnical engineer shall provide continuous on-site observations by expedient personnel during construction of corrected earthwork. Refer to structural recommendations for suggested site prep and consult a geotechnical engineer as required.

(1) All slabs on grade and structure footings

4) Unless otherwise indicated, concrete cover shall be:

- a) Foundations _____"
- b) Slabs (Not exposed to weather) _____"

II. QUALITY ASSURANCE & STATEMENT OF SPECIAL INSPECTION

- A. The contractor shall engage qualified independent inspectors to implement special inspection. Special inspection shall conform to the IBC, chapter 17.
- B. After each inspection and test, promptly furnish copy of laboratory report to owner, architect/engineer, and to contractor. Report shall include:
 1. Date tested, Project title and number, Name of Inspector, Date and time of sampling or inspection, Identification of project specifications section, Location of project, Type of inspection or test, Date of tests, Results of tests, Conformance with contract documents.

C. Required Inspections:

1. Soils - as outlined in Division Specifications Section titled "Foundation Notes"
2. Concrete - as outlined in the Division Specifications Section titled "Structural Concrete"
 - a) Installation of embedded bolts and plates supporting structure
 - b) Reinforcing steel placement
 - c) Field bending of reinforcing steel
 - d) Reinforcing couplers
 - e) Anchored rebar or expanded rebar into hardened concrete
3. Wood
 - a) Hold down anchor/straps
 - b) Shear wall/Chimneyra bracing
 - c) Metal connectors
- D. Special Inspection to be provided in addition to inspections conducted by the building department and shall not be construed to relieve the contractor of its contractual obligation to provide the period and extent of inspections required by section 1704 of the International Building Code.
1. Pretests inspection to be provided in addition to inspections conducted by the building department and shall not be construed to relieve the contractor of its contractual obligation to provide the period and extent of inspections required by section 1704 of the International Building Code.
2. Special Inspection is required for the following:
 - a) Steel construction
 - (1) High strength bolts
 - (2) Welding
 - (3) Structural Steel & Cold-Formed Steel Deck
 - b) Concrete construction
 - (1) Reinforcing steel
 - (2) Bolts installed prior to and during concrete placement
 - (3) Mix design(s)
 - (4) All the fresh concrete to be sampled
 - (5) Inspection of concrete placement
 - (6) Inspection for maintenance of specified curing techniques
 - c) Special case
 - (1) Expansion or adhesive concrete

III. SHOP DRAWINGS SUBMITTAL

- A. Contractor to submit to Structural Engineer
 1. Concrete Mill Design
 2. Anchor bolts
 3. Reinforcing Bars

D. All shop drawings and submittals must be reviewed and stamped by the contractor prior to submittal. Shop drawings and submittals shall be accompanied by sealed calculations as required by the specifications. No fabrications shall proceed before shop drawings covering that work have been approved. Allow at least 10 days for shop drawing review.

IV. STRUCTURAL CONCRETE

- A. All concrete elements shall be finished 3/4" on exposed surfaces unless otherwise noted.
- D. Details for design, strength at 28 days:
 1. Unless indicated otherwise, all concrete shall be ready-mixed concrete with standard stone aggregate (144 PCF), and Type II cement-High early strength when desired.
 2. All structural steel conform to the requirements of ACI 318-14 Table 19.3.3.1.
 3. Structural design to be based upon ACI 318-14 and construction shall conform to ACI 301 and ACI 302.
 - a) $f'_c = 4000 \text{ psi (normal weight)}$
 - b) $f_y = 60,000 \text{ psi (normal weight)}$
 4. Unless otherwise indicated, concrete cover shall be:
 - a) Foundations _____"
 - b) Slabs (Not exposed to weather) _____"

C. REINFORCING STEEL

1. Deformed Bars _____ ASTM A615 / Grade 60
2. Placing of reinforcing steel conform to ACI 318, table 19.3.3.1.
3. All reinforcing steel to be held secure in position with standard accessories during placing of concrete.
4. Cast and beam bottom and tie-chairs shall have vinyl-coated hooked-up legs where available/available of slab is exposed.
5. All field bending of reinforcing shall be done cold. Bending of bars will not be permitted.
6. Unless otherwise indicated, splice reinforcing as follows:
 - a) Reinforcing Bars _____ AS Bar Diameter
 - b) Welded Wire Fabric _____"

D. WALLS

1. Exposed site walls, retaining walls, and stem walls greater than 30 feet in length shall have control joints installed and spaced no greater than 25 feet on center. Install joints within 10 feet of all wall corners.
2. Contractor shall submit to architect, final locations of all control joints for approval, prior to construction.

E. SLAB-ON-GROUND CRITERIA

1. Slab thickness to the specified clear-to-clear ratio of 0.44 is required. Vibration shall not be added to the rate of the placement.
2. Shrinkage shall not exceed 0.02% per ASTM C 157 at 28 days. Shrinkage-compensating concrete shall conform to the recommendations of ACI 223.
3. Moist curing of slab-on-ground is required.
4. Care shall be taken to prevent water intrusion into the subgrade both prior to and after slab pour.
5. Construction joints (control joints) shall be installed on all concrete slabs on grade. Verify location of all joints with architect prior to placing concrete. The joints shall be spaced no further than 36 times the slab thickness or 15 ft, L or T shapes be embedded within crack control joints. If the shape of the area controlled by the crack control joints is not square, the aspect ratio of this area should not exceed 1.5 to 1. The control joints shall be placed such that they are continuous and not staggered or offset. Placements shall be in accordance to ACI 302.1.
6. Timing of early entry slab saw cuts is critical to slab curing performance. Saw cuts for control joints (construction joints) shall be made at the earliest possible time that the concrete will bear the weight of saw cutting equipment and operators. Timing of early entry saw cuts shall vary between 1 hour in hot weather and 4 hours in cold weather. Early entry saw cuts shall vary between a 1/2 inch to 1 inch into the depth of the slab. The slab shall be cut to 1/4 of the slab depth to deepen the 1 inch normal early entry saw cut within 24 hours.
7. A construction or access road down all construction joints shall be placed at a maximum of 12 ft.
8. All joints shall be filled to the full joint depth with non-shrink joint filler in areas exposed to vehicular traffic. Overlaid joints and slab joints shall not be broom finished.

F. CONCRETE PLACEMENT & TESTING

1. Unless otherwise indicated, the test cylinders shall be made every City cubic yard of concrete or fraction thereof on each day's pour. One cylinder shall be tested at 7 days and three at 28 days. The remaining cylinders shall be held in reserve as a spare. The making and testing of cylinders shall be conducted by an approved testing laboratory; contractor shall bear the cost of testing.
 - a) Before test sampling and placing concrete, water may be added to Project site, subject to restrictions of ACI 301.
 - b) Do not add water to concrete after adding high-range water-reducing admixture to mixture.
2. Concrete shall be placed using mechanical vibrating equipment according to ACI 301.
3. Do not use vibrators to transport concrete into forms. Insert and withdraw vibrators vertically at uniformly spaced locations to rapidly penetrate placed layer and at least 6 inches into preceding layer. Do not insert vibrators into lower layers of concrete that have begun to lose plasticity. At each insertion, limit duration of vibration to the minimum necessary to consolidate concrete and complete embedment of reinforcement and other embedded items without causing excessive consolidation or segregation.
4. Maintain all reinforcement in position on chairs during concrete placement.

G. COLD WEATHER CONCRETING

1. All cold weather concrete work shall meet the requirements of ACI Concrete 308, latest edition for cold weather concreting. It is for 3 consecutive days the average daily temperature drops below 40°F and stays below 40°F for more than one-half of any 24 hour period.
2. Do not use frozen materials including ice or snow.
3. Do not place concrete on frozen subgrade or on subgrade containing frozen materials.
4. The use of calcium chloride, salt, or other materials containing chloride agents or chemical accelerators is not permitted; contractor shall utilize a high early strength mix design.

H. HOT WEATHER CONCRETING

1. All hot weather concrete work shall be in accordance with ACI 301. Minimum concrete temperature below 60°F at time of placement. Chilled mixing water or crushed ice may be used to control temperature, provided water equivalent of ice is calculated to total amount of mixing water.
2. Fog-spray hoses, steel reinforcement, and subgrade just before placing concrete. Keep subgrade uniformly moist without standing water, wet coats, or dry areas.

I. EMBEDDED CONDUIT

1. Embedded conduits and/or pipes shall not be installed in slabs or columns, unless approved by the structural engineer, prior to construction.
2. Conduits and/or pipes shall be protected against rusting. Aluminum conduits and/or pipes shall not be embedded in concrete.

V. CARPENTRY

- A. Dimensional lumber shall conform to the grading standard of the Western Wood Products Association (WWPA), surface dry, seasoned 30 days, and 10 percent maximum moisture content.
1. Wood-Pressure-Treated Lumber shall be utilized as follows:
 - a) Joists in contact with concrete or masonry.
 - b) Framing less than 10' above ground in crawlspaces.
 - c) Floor plates installed over concrete slabs-on-grade.
2. Preservative Treatment: AMPA C2 with chemicals containing no arsenic or chromates.
3. AMPA C31 borate-based preservative may be used in protected locations.
- B. Wood Design Values
 1. Hm3 Fir #2 (posts, floor framing and roof framing)
 - a) $F_y = 480 \text{ psi}$, $F_x = 425 \text{ psi}$, $P_y = 1,300 \text{ psi}$, $E = 1,900,000 \text{ psi}$
 2. Red sheathing shall be 1/2" O.D. Structural 1, unbleached. Nailing pattern = 10d common nails @ 16" on edges and 12" on end. Field use supporting clips, NAIL. Fire rated O.D.S. shall be provided to 4'-0" on each side of party walls at the roof level.
 3. Wall sheathing shall be 7/16" O.D. Structural 1, unbleached. Nailing pattern = 8d common nails @ 16" on edges and 12" on end. 10d UOM.
 4. Plywood backing panels for telephone and electrical equipment.
- E. All pre-cast concrete (Gypsum, etc.) shall be fully installed using type, size and quantity specified by the manufacturer. All interior connections shall be gasketed. General contractor to submit connection schedule to architect/engineer prior to installation.

C. FASTENING

1. All fastening to be in accordance with IBC Fastening Schedule Table 2534.10.1, UOM.

VI. POST-INSTALLATION ANCHORS

- A. Except where indicated on the drawings, post-installed anchors shall consist of the following anchor types as provided by Simpson Strong-Tie Company, Inc.
 1. Anchorage to concrete
 - a) Adhesive anchors for cracked and uncracked concrete with Set-300™ technology:
 - (1) Simpson Strong-Tie HPS/HP-10 adhesive anchoring system installed using the Simpson cast-in-place bit meeting the diameter requirements of ANSI D12.15.
 - b) Adhesive anchors for cracked and uncracked concrete with standard cleaning procedures:
 - (1) Simpson Strong-Tie Adhesive anchoring system with HAS-E Etched rod or deburred rods per ICC-ES ESR-2208 for cast-in-place applications.
 - (2) Simpson Strong-Tie Adhesive anchoring system with HAS-E Etched rod or deburred rods per ICC-ES ESR-2208 for slow-cure applications.
 - c) Adhesive anchors used in design shall be based on the technical data published by Simpson Strong-Tie for each product as approved by the structural engineer of record. Evaluation requests for alternate products must be approved in writing by the structural engineer of record prior to use. Contractor shall provide calculations demonstrating that the substituted product is capable of achieving the performance criteria of the specified product. Substitutions will be evaluated by their having an ICC-ES ESR showing compliance with the relevant building code for seismic use, load resistance, installation category, and availability of comprehensive installation instructions. Adhesive anchor evaluation will also consider creep, shrinkage, temperature and installation temperature.
 2. Anchorage to solid grout/masonry
 - a) Adhesive anchors use:
 - (1) Simpson Strong-Tie HPS/HP-10 adhesive anchoring system installed using the Simpson cast-in-place bit meeting the diameter requirements of ANSI D12.15.
 - (2) Steel anchor elements shall be Simpson HAS-E continuously etched rod or continuously etched steel rebar.
 - b) Mechanical anchors use:
 - (1) Simpson Titenard™ per ICC-ES ESR 1638
 - (2) Simpson Titenard™ per ICC-ES ESR 1390
 - B. Anchor capacity used in design shall be based on the technical data published by Simpson Strong-Tie for each product as approved by the structural engineer of record. Evaluation requests for alternate products must be approved in writing by the structural engineer of record prior to use. Contractor shall provide calculations demonstrating that the substituted product is capable of achieving the performance criteria of the specified product. Substitutions will be evaluated by their having an ICC-ES ESR showing compliance with the relevant building code for seismic use, load resistance, installation category, and availability of comprehensive installation instructions. Adhesive anchor evaluation will also consider creep, shrinkage, temperature and installation temperature.
 - C. Install anchors per the manufacturer's instructions, as included in the anchor packaging.
 - D. Anchor capacity is dependent upon spacing between adjacent anchors and proximity of anchors to edge of concrete. Install anchors in accordance with spacing and edge clearances indicated on the drawings.
 - E. Existing reinforcing bars in the concrete structure may conflict with specific anchor locations. Unless noted on the drawings that the bars can be cut, the contractor shall review the existing structural drawings and shall coordinate to locate the position of the reinforcing bars at the locations of the concrete anchors, CPY, rebar, clipping, or other rebar.

NAVAJO NATION BATHROOM ADDITIONS
 NAVAJO NATION
 CONSTRUCTION DOCUMENTS
 NAVAJO NATION
 BUREAU OF CONSTRUCTION AUTHORITY

INDIGENOUS DESIGN STUDIO +
 ARCHITECTURE, LLC
 6008 Pecos/Azusa Cir NE
 Albuquerque, NM 87110
 Tel 505.228.2565
 Fax 505.228.2500

CONSTRUCTION SET

ARCHITECT

MARK	DATE	DESCRIPTION

PROJECT NUMBER: ND-30
 DRAWING FILE:
 DRAWN BY: JMS
 CHECKED BY: ACS / JCS
 COPYRIGHT 2020 Indigenous Design Architecture, LLC

OUTLINE SPECIFICATIONS

SHEET NUMBER

S001

Scale of

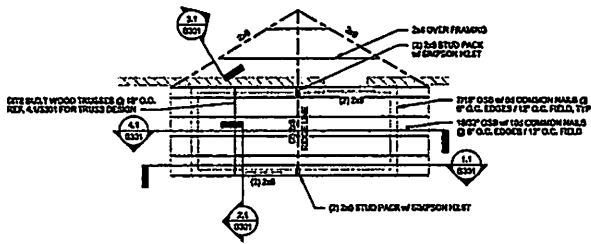

1 Roof Framing A GABLE TRUSS ROOF
1/4" = 1'-0"

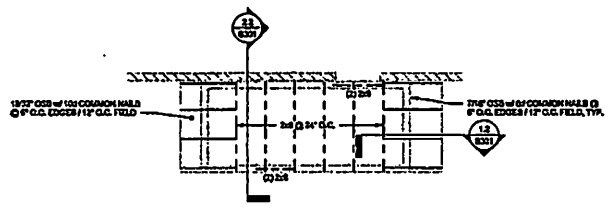

2 Roof Framing B MONOSLOPE ROOF
1/4" = 1'-0"

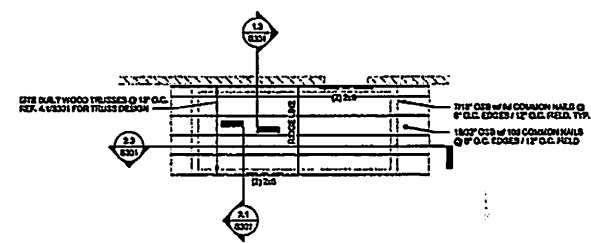

3 Roof Framing C GABLE TRUSS ROOF
1/4" = 1'-0"

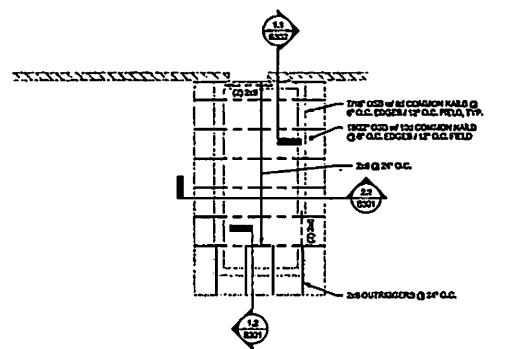

4 Roof Framing D MONOSLOPE ROOF
1/4" = 1'-0"

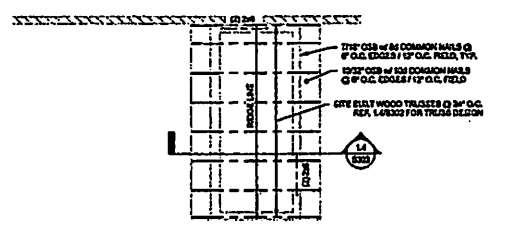

5 Roof Framing E GABLE TRUSS ROOF
1/4" = 1'-0"

NAVAJO NATION BATHROOM ADDITIONS
NAVAJO NATION
CONSTRUCTION DOCUMENTS

OWNER: NAVAJO NATION
CONSTRUCTION AUTHORITY

INDIGENOUS DESIGN STUDIO + ARCHITECTURE, LLC
6008 Pennsylvania Circle NE
Albuquerque, NM 87110
Tel 505.228.2563
Fax 505.228.2560

CONSTRUCTION SET

ARCHITECT

MARK	DATE	DESCRIPTION

PROJECT NUMBER: MD-36
DRAWING FILE: JAR
DRAWN BY: JAR
CHECKED BY: AEL/JAR
COPYRIGHT 2020 Indigenous Design Studio + Architecture, LLC.

SHEET TITLE
ROOF FRAMING

SHEET NUMBER
S102

D:\000000\115E\Comp\Arch\DWG\ECN - 150 Bathroom\SEC4 - 150 Bathroom - 8.11.2019.dwg

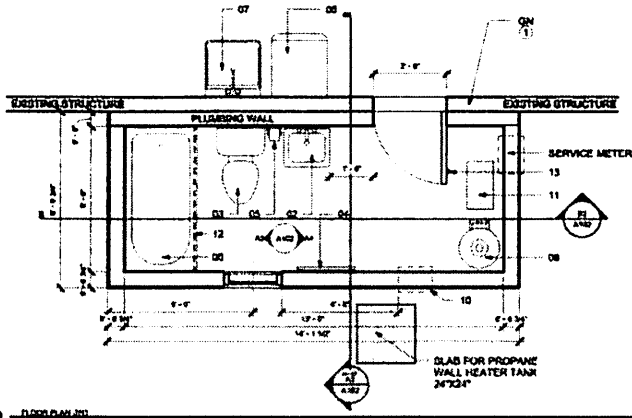

GN 1 - FLOOR PLAN (A) 12' x 14'

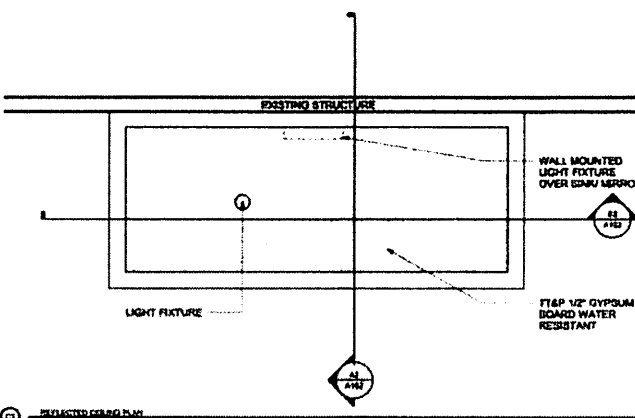

GN 2 - ROOF PLAN (A) 12' x 14'

GENERAL NOTES

GN 1 - FLOOR PLAN OPTION TO BE USED WHERE ADJOINING EXISTING WALL IS GREATER OR EQUAL TO 12' 0".

GN 2 - FLOOR PLAN OPTION TO BE USED WHERE ADJOINING EXISTING WALL IS LESS THAN 12' 0".

GN 3 - ROLL ROOFING IS TO BE INSTALLED ON ROOFS WHOSE SLOPE NO LESS THAN 0' 2 1/4" 1' 0" AND NO MORE THAN 0' 4" 1' 0". ASPHALT SHINGLES ARE TO BE INSTALLED ON ROOFS WHOSE SLOPE IS NO LESS THAN 0' 4" 1' 0".

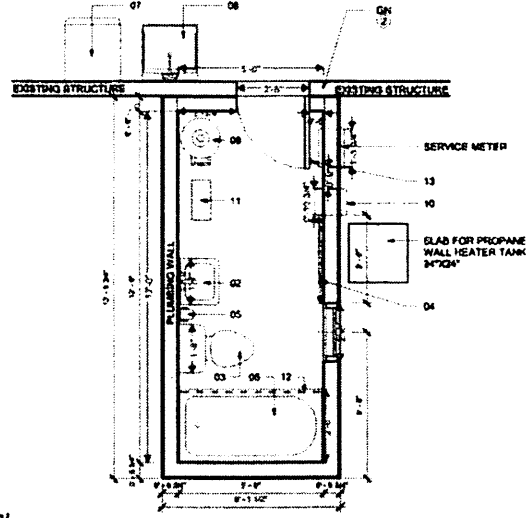

GN 3 - FLOOR PLAN (A) 12' x 14'

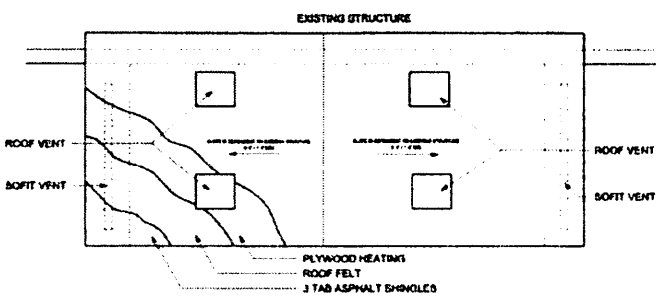

GN 3 - ROOF PLAN (A) 12' x 14'

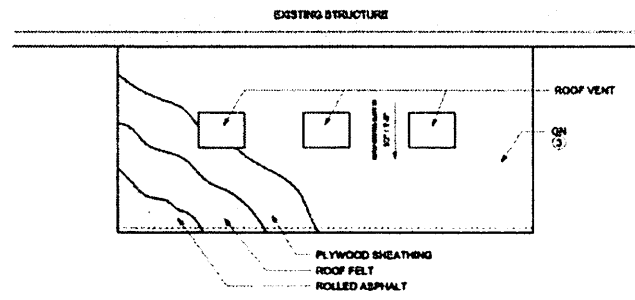

GN 4 - ROOF PLAN (A) 12' x 14'

Material and Finish Schedule

Key	Name	Type	Manufacturer	Model Number	Color
01	Wall	Plaster	USG	1/2\"/>	

Fixture Schedule

Key	Name	Type	Manufacturer	Model Number	Finish
01	Vanity Cabinet	W/C	4830		White
02	Sink	Porcelain	2541		White
03	Shower Pan	Acrylic	10715		White
04	Shower Head	Chromed	18442		Chromed
05	Shower Valve	Chromed	10715		White
06	Shower Head	Chromed	18442		Chromed
07	Shower Valve	Chromed	10715		White
08	Shower Head	Chromed	18442		Chromed
09	Shower Valve	Chromed	10715		White
10	Shower Head	Chromed	18442		Chromed
11	Shower Valve	Chromed	10715		White
12	Shower Head	Chromed	18442		Chromed
13	Shower Valve	Chromed	10715		White
14	Shower Head	Chromed	18442		Chromed
15	Shower Valve	Chromed	10715		White
16	Shower Head	Chromed	18442		Chromed
17	Shower Valve	Chromed	10715		White
18	Shower Head	Chromed	18442		Chromed
19	Shower Valve	Chromed	10715		White
20	Shower Head	Chromed	18442		Chromed
21	Shower Valve	Chromed	10715		White
22	Shower Head	Chromed	18442		Chromed
23	Shower Valve	Chromed	10715		White
24	Shower Head	Chromed	18442		Chromed
25	Shower Valve	Chromed	10715		White
26	Shower Head	Chromed	18442		Chromed
27	Shower Valve	Chromed	10715		White
28	Shower Head	Chromed	18442		Chromed
29	Shower Valve	Chromed	10715		White
30	Shower Head	Chromed	18442		Chromed
31	Shower Valve	Chromed	10715		White
32	Shower Head	Chromed	18442		Chromed
33	Shower Valve	Chromed	10715		White
34	Shower Head	Chromed	18442		Chromed
35	Shower Valve	Chromed	10715		White
36	Shower Head	Chromed	18442		Chromed
37	Shower Valve	Chromed	10715		White
38	Shower Head	Chromed	18442		Chromed
39	Shower Valve	Chromed	10715		White
40	Shower Head	Chromed	18442		Chromed
41	Shower Valve	Chromed	10715		White
42	Shower Head	Chromed	18442		Chromed
43	Shower Valve	Chromed	10715		White
44	Shower Head	Chromed	18442		Chromed
45	Shower Valve	Chromed	10715		White
46	Shower Head	Chromed	18442		Chromed
47	Shower Valve	Chromed	10715		White
48	Shower Head	Chromed	18442		Chromed
49	Shower Valve	Chromed	10715		White
50	Shower Head	Chromed	18442		Chromed
51	Shower Valve	Chromed	10715		White
52	Shower Head	Chromed	18442		Chromed
53	Shower Valve	Chromed	10715		White
54	Shower Head	Chromed	18442		Chromed
55	Shower Valve	Chromed	10715		White
56	Shower Head	Chromed	18442		Chromed
57	Shower Valve	Chromed	10715		White
58	Shower Head	Chromed	18442		Chromed
59	Shower Valve	Chromed	10715		White
60	Shower Head	Chromed	18442		Chromed
61	Shower Valve	Chromed	10715		White
62	Shower Head	Chromed	18442		Chromed
63	Shower Valve	Chromed	10715		White
64	Shower Head	Chromed	18442		Chromed
65	Shower Valve	Chromed	10715		White
66	Shower Head	Chromed	18442		Chromed
67	Shower Valve	Chromed	10715		White
68	Shower Head	Chromed	18442		Chromed
69	Shower Valve	Chromed	10715		White
70	Shower Head	Chromed	18442		Chromed
71	Shower Valve	Chromed	10715		White
72	Shower Head	Chromed	18442		Chromed
73	Shower Valve	Chromed	10715		White
74	Shower Head	Chromed	18442		Chromed
75	Shower Valve	Chromed	10715		White
76	Shower Head	Chromed	18442		Chromed
77	Shower Valve	Chromed	10715		White
78	Shower Head	Chromed	18442		Chromed
79	Shower Valve	Chromed	10715		White
80	Shower Head	Chromed	18442		Chromed
81	Shower Valve	Chromed	10715		White
82	Shower Head	Chromed	18442		Chromed
83	Shower Valve	Chromed	10715		White
84	Shower Head	Chromed	18442		Chromed
85	Shower Valve	Chromed	10715		White
86	Shower Head	Chromed	18442		Chromed
87	Shower Valve	Chromed	10715		White
88	Shower Head	Chromed	18442		Chromed
89	Shower Valve	Chromed	10715		White
90	Shower Head	Chromed	18442		Chromed
91	Shower Valve	Chromed	10715		White
92	Shower Head	Chromed	18442		Chromed
93	Shower Valve	Chromed	10715		White
94	Shower Head	Chromed	18442		Chromed
95	Shower Valve	Chromed	10715		White
96	Shower Head	Chromed	18442		Chromed
97	Shower Valve	Chromed	10715		White
98	Shower Head	Chromed	18442		Chromed
99	Shower Valve	Chromed	10715		White
100	Shower Head	Chromed	18442		Chromed

Door Schedule

Type	Manufacturer	Model	Finish	Color
1	USG	1/2\"/>		

Window Style Schedule

Window Type	Window Model	Window Type	Window Height	Window Width	Comments
1	USG	1/2\"/>			

NAVAJO NATION BATHROOM ADDITIONS
 NAVAJO NATION
 CONSTRUCTION DOCUMENTS
 CHANGE: NAVAJO ENG. & CONSTRUCTION AUTHORITY

INDIVIDUAL DESIGN STUDIO + ARCHITECTURE, LLC
 8008 Pennsylvania Cir NE
 Albuquerque, NM 87110
 Tel 505.226.2580
 Fax 505.226.2580

NO.	DATE	DESCRIPTION

PROJECT NUMBER: MO-30
 DRAWING FILE:
 DRAWN BY:
 CHECKED BY:

SHEET FLOOR, ROOF PLANS & SCHEDULES

SHEET NUMBER
A101

ELECTRICAL, MECHANICAL & PLUMBING OUTLINE SPECIFICATIONS

MECHANICAL AND PLUMBING

- 1. THESE DRAWINGS MUST ACCOMPANY THE PUBLISHED CONSTRUCTION DOCUMENT.
2. DO NOT SCALE DRAWINGS. VERIFY DIMENSIONS IN FIELD PRIOR TO COMMENCEMENT OF WORK. REFER TO ARCHITECTURAL DRAWINGS FOR ALL DIMENSIONS.
3. ALL SUBCONTRACTORS SHALL BE LICENSED, EXPERIENCED, AND THOROUGHLY KNOWLEDGEABLE IN THEIR RESPECTIVE FIELDS OF THE CONSTRUCTION INDUSTRY AND SHALL PERFORM IN A RESPONSIBLE MANNER WITH ESTABLISHED CONSTRUCTION ETHICS. EACH SHALL MAINTAIN THE PROHIBITION OF THE CONSTRUCTION DOCUMENTS, AND SHALL REPORT THE PRIME CONTRACTOR OF ANY POTENTIAL PROBLEMS WHEN THE CONSTRUCTION DOCUMENTS ARE UNCLEAR OR INCONCLUSIVE.
4. COORDINATION OF ISSUING DOCUMENTS:
4.1. EACH SUBCONTRACTOR SHALL EXAMINE THE ISSUING DOCUMENTS CAREFULLY, AND NOT LATER THAN SEVEN (7) DAYS PRIOR TO THE DATE OF RECEIPT OF BIDDING DOCUMENTS. IF ANY DISCREPANCY TO THIS ARCHITECT FOR INTERPRETATION OR CORRECTION OF ANY DISCREPANCY, AMBIGUITY, INCONSISTENCY, OR ERROR IS DISCOVERED WHICH THEY HAVE DISCOVERED, THE ARCHITECT WILL ISSUE ANY INTERPRETATION OR CORRECTION AS AN ADDENDUM. ONLY A WRITTEN INTERPRETATION OR CORRECTION BY ADDENDUM SHALL BE BINDING. NO SUBCONTRACTOR SHALL RELY ON INTERPRETATIONS OR CORRECTIONS GIVEN BY ANY OTHER SOURCE.
4.2. FAILURE TO REQUEST CLARIFICATION DURING THE BID PERIOD OF ANY DISCREPANCY, AMBIGUITY, OR ERROR WILL NOT RELIEVE THE CONTRACTOR OF HIS RESPONSIBILITIES.
4.3. PROVIDE A BASIS BID WHICH SHALL INCLUDE ONLY SPECIFIED EQUIPMENT OR MATERIALS. NO EQUIPMENT OR MATERIALS NOT LISTED FOR THE LISTED EQUIPMENT SHALL BE ALLOWED IN THE BASIS BID.
4.4. THE MANUFACTURER OF EQUIPMENT OR MATERIALS FIRST NAMED ON THE DRAWINGS AS THE BASIS OF DESIGN, OTHER MANUFACTURES LISTED ARE CONSIDERED EQUAL EQUIVALENTS ONLY. PROVIDE NECESSARY ADDITIONAL ITEMS GO TO THE BASIS OF DESIGN AND IDENTIFIED ITEM OPERATIONS LISTED TO THE BASIS OF DESIGN AND PROPERLY FIT IN THE AVAILABLE SPACE ALLOCATED FOR THE BASIS OF DESIGN.
4.5. PROVIDE ALL FEATURES WHICH ARE STANDARD ON THE BASIS OF DESIGN PLUS ANY SPECIFIED OPTIONS.
4.6. THE CONTRACTOR SHALL BE RESPONSIBLE FOR THE LOCATION OF TRAP, CONDENSATE, DUCT, FLEX, AND OTHER SERVICE LOCATIONS FOR GENERAL EQUIVALENTS OR SUBSTITUTIONS DO NOT CAUSE ACCESS, SERVICE, OR OPERATIONAL DIFFICULTY. ANY OTHER TRADES SHALL BE COORDINATED WITH THE BASIS DESIGN.
4.7. OFFSET PIPING, DUCTWORK, ETC. AS NECESSARY TO ACCOMMODATE STRUCTURE, BEAMS, AND COLLARS, AND TO MEET THE SATISFACTION OF THE ARCHITECT, OWNER, AND ENGINEER.
4.8. THE CONTRACTOR SHALL BE RESPONSIBLE TO PERFORM ALL MECHANICAL WORK IN CONFORMANCE WITH ALL APPLICABLE CODES, ORDINANCES AND LIFE SAFETY FEATURES AS REQUIRED BY LOCAL, STATE, OR NATIONAL AUTHORITIES. THE CONTRACTOR SHALL VERIFY WITH THE ARCHITECT BY INSPECTION OF FRESH WORK IS REQUIRED FOR COMPLIANCE.
4.9. SUBMIT RECORD DRAWINGS TO ARCHITECT. DOCUMENTS SHALL INCLUDE ALL APPROPRIATE, CHANGE ORDERS, ALTERNATES, ADDENDUMS, ETC.
4.10. SYSTEMS SHALL BE COMPLETE, OPERABLE, AND READY FOR CONTINUOUS OPERATION FROM THE START.
4.11. SYSTEMS SHALL BE TESTED FOR PROPER OPERATION. PERFORM AT A MINIMUM ALL CODES REQUIRED TESTS ON SYSTEMS. IF TESTS OF WORK ARE DEFECTIVE, CONTRACTOR SHALL MAKE CORRECTIONS NECESSARY AT NO ADDITIONAL COST TO OWNER.
4.12. ALL MATERIALS AND/OR EQUIPMENT SHALL BE HANDLED AND INSTALLED AS PER MANUFACTURERS SPECIFICATIONS AND RECOMMENDATIONS.
4.13. PROVIDE NECESSARY TRENCHING, BACKFILL, EXCAVATION, SUPPORT, SAW-CUTTING AND PATCHING, CONCRETE PATCHING, ETC., AS REQUIRED. BACKFILL TRENCHES IN 4" LAYERS AND TO THE CORRECTION AND PATCH TO MATCH EXISTING GRADE.
4.14. CAREFULLY VERIFY ELECTRICAL SERVICE VOLTAGE AND PHASE AVAILABLE.
4.15. FLEXIBLE DUCTWORK SHALL HAVE AN OUTER JACKET OF FIRE RETARDANT POLYETHYLENE VAPOUR BARRIER MATERIAL, AN INNER LAYER OF FIBREGLASS INSULATION, FIBREGLASS CALUMINATE ETC., HOLE DRUMS, AND AN INTERIOR "TOP STOP" ALUMINUM LAMINATE INTERIOR CORE, UL LISTED AND LABELED, CLASS A FIRE RATED, FLEXIBLE CONNECTIONS EQUIVALENT TO VENTILATION FIRE-PROOF GLASS GLAZING, 1 1/2" W.C. RATED.
4.16. ROUND DUCT: SPIRAL SEAM GALVANIZED STEEL. BE STAMPED OR BORE ELONGATE. 1" MINIMUM LONGITUDINAL SEAM GUESS, OR ACCEPTABLE FITTINGS ARE ACCEPTABLE ON INDIVIDUAL COLLECTOR/USER RADIANTS ONLY.
4.17. DUCTWORK: 60 GALVANIZED SHEET STEEL; LOCK FORMING QUALITY, CONSTRUCTED TO THE LATEST EDITION OF SMANNA WIND DUCT CONSTRUCTION (STANDARD); 1/2" W.C. PRESSURE CLASSIFICATION, SEAL CLASS "C" WITH GALVANIZED STEEL FASTENERS, ANCHORS, ANGLES, STAIRS, ETC.
4.18. SEAL ALL SEAMS (LONGITUDINAL AND TRANSVERSE) AIRTIGHT WITH UNITS MOULD "1/4" OR "1/2" UL LISTED, WATER BASED, NON-HARDENING, ELASTIC DUCTWORK GLOW WELCITY.
4.19. PROVIDE 1/4" GALVANIZED MESH SCREEN ON ALL COMBUSTION AIR DUCTS OR OPENINGS, AND ALL OPEN END RETURN AND EXHAUST DUCTS.
4.20. ALL DUCTWORK SHALL BE 1/2" INSIDE THE AREA DIMENSIONS.
4.21. SUPPORT PIPE WITH ROD AND CLAMP, FISH HANGERS, TRAPESSE, OR CLAMPS. NO JOINT TAPES OR STRAPPING ALLOWED. ALL HANGERS SHALL BE SIZED FOR THE LOADS. USE 1/4" DIA. GALVANIZED STEEL OR 1/2" DIA. GALVANIZED STEEL OR 1/4" DIA. GALVANIZED STEEL METAL SHEETS FOR PIPING 1/2" AND LESS. PROVIDE GALVANIZED BRACKET INSULATION SUPPORTS FOR UNINSULATED PIPING 1/2" AND LARGER. MATHEN VAPOR BARRIER ON ALL COOLD LINES. ISOLATE ALL WATER PIPING LINES FROM HANGERS WITH MEMBRANE OR EQUIVALENT, COPPER COATED HANGERS ARE NOT SUFFICIENT. WRAP PIPING WITH TAPE NOT ACCEPTABLE.
4.22. COPPER PIPE VALVES AND SPECIES:
4.23. 1. GATE VALVES - BRONZE, CLASS 125, 200 LB. W.O.G.
4.24. 2. BALL VALVES - BRONZE, CLASS 125, 200 LB. W.O.G.
4.25. 3. CHECK VALVES - BRONZE, CLASS 125, 200 LB. W.O.G.
4.26. 4. BALANCING VALVES - 125 PSI W.P. FOR 200 DEGREE FAHRENHEIT SERVICE TRIM: BRASS, TON AND ANDERSON, ETC., ADJUSTING: GEAR, GEAR, OR FLOWMETER, BALL AND GOSSETT CHECK SEITLER.
4.27. DIRECT UNIONS: FURNISH AND INSTALL A DIRECT UNION AT EACH CONNECTION BETWEEN DISJUNCT METALS.

- 22. MATERIALS: SOIL, WASTE, AND VENT PIPING (INSIDE BUILDING)
23. 1. LINES ABOVE GROUND: MINIMUM WEIGHT, CL 602, PIPE AND FITTINGS. NO HUB WITH HEAVY DUTY FLANGE. UP THROUGH 2-1/2" MAY BE STANDARD WEIGHT, GALVANIZED STEEL PIPE WITH BLACK W/L. DRAW FITTINGS, OR DRY COPPER TUBE WITH DRY FITTINGS AND BUSHING JOINTS.
23.2. CONDENSATE DRAIN LINES INSIDE BUILDING TO BE COPPER TUBE WITH 1/8" NO LEAD GALDOR.
23.3. CONDENSATE DRAIN LINES OUTSIDE BUILDING TO BE PVC WITH UNAPPROPRIATE COATING, LATEX PAINT OR EQUAL.
24. GAS PIPING - SCHEDULE 40 BLACK STEEL PIPE, WELDED FITTINGS WITH ALL PIPING COATED AND WRAPPED ON EXPOSED PIPE.
25. GAS VALVES - NON-LUBRICATED BALL STYLE VALVE WITH RESILIENT SEATS, AND ADJUSTABLE GROUND PACKING NUT, ASA AND UL LISTED FOR NATURAL GAS SERVICE.
26. DRAWN PAN PIPING - NOT BURIED - TYPE "M" COPPER, WROUGHT COPPER FITTINGS, AND 1/8" GASKETS.
27. SUPPORT DRAIN INSULATED CISTERN PLUMB BY HAZON INDUSTRIES OR EQUIVALENT SPRING TYPE ESPECIALLY RESTRAINED VAPORATION ISOLATORS. INSULATE ALL DOMESTIC HOT AND COLD WATER PIPING WITH UL LISTED, FIBREGLASS, WHITE, ALL GROUND, CLASS FIBRE INSULATION. INSULATE FITTINGS WITH GLASS FIBRE INSULATION AND PROLONGED P.V.C. COVERS. ALL MATERIALS SHALL HAVE A BURNING DEVELOPED RATING OF 0 OR LESS AND A FLAME SPREAD RATING OF 25 OR LESS. INSULATION SHALL PASS UNINTERRUPTED THROUGH HANGERS. VAPOR BARRIERS SHALL BE CONTINUOUS AND SEALED WITH "NONMATERIAL" MASTIC OR GOLF PENCIL. ALL RAW EDGES OF INSULATION SHALL BE NICELY TRIMMED AND SEALED WITH MASTIC.
28. 1. INSULATION THICKNESS:
28.1. 1. DOMESTIC COLD WATER: 1" THICK
28.2. 2. DOMESTIC HOT WATER: 1" THICK
28.3. 3. EXTERIOR HOT WATER: 1" THICK FLEXIBLE ELASTOMER
29. EQUIPMENT LABELS: LABEL ALL PIPING AND EQUIPMENT. PROVIDE FULL DIM AND OR TOP TYPE MARKERS AND FLEXI ARROWS ON PIPING. PROVIDE ENGRAVED PLASTIC VALVE TAGS WITH VALVE NUMBER AND ATTACH WITH STANDARD CHAIN OR SHOOK. PROVIDE ENGRAVED PLASTIC SIGN ON OR NEAR SPECIFIED EQUIPMENT.
30. FIRE PROTECTION DESIGN/NOTED REQUIREMENTS:
31. 1. PROVIDE NEW AUTOMATIC SPROKLER SYSTEM TO FULLY PROTECT BUILDING. COMPLETE DRAWINGS, SPECIFICATIONS, AND DETAILS SHALL BE SUBMITTED BY THE FIRE SPROKLER DESIGNER/INSTALLER TO THE ARCHITECT. THE FIRE SPROKLER CONTRACTOR SHALL ADVISE AS THE DESIGNER OF RECORD FOR ALL WORK PERFORMED UNDER THIS DESIGN. IF REQUIRED BY THE ARCHITECT, THE CONTRACTOR SHALL PROVIDE A SPROKLER SYSTEM SHOP DRAWINGS AND HYDRAULIC CALCULATIONS, COMPLETED BY CONTRACTOR. SHOP DRAWINGS SHALL BE A MINIMUM 1/4" SCALE, AND SHALL SHOW DEVICE AND APPLIANCE LOCATIONS, SMOKE BACKDROPP INFORMATION, ROOM OCCUPANCY DESCRIPTIONS, DOOR SWINGS, FIRE RATINGS AND FIRE PROTECTION SYSTEM LAYOUT AND DETAILS. SHOP DRAWINGS AND HYDRAULIC CALCULATIONS SHALL BE SEALED BY A REGISTERED PROFESSIONAL ENGINEER OR PROFESSIONAL ENGINEER REGISTERED IN THE STATE OF ARIZONA. SUBMIT SHOP DRAWINGS AND HYDRAULIC CALCULATIONS TO THE BUILDING AND FIRE DEPARTMENT AS A DEFERRED SUBMITTAL AND OBTAIN THEIR APPROVAL BEFORE SUBMISSION TO THE ARCHITECT.
32. WHERE REQUIRED BY THE A.H.J., ALL NEW SPROKLER HEADS SHOULD HAVE THE CONNECTING MAN AND BRANCH PIPE SIZES SHOWN.
33. 1. SHOW THE CONNECTING MAN AND BRANCH PIPE SIZES FOR ALL NEW SPROKLER HEADS.
33.2. CONFORM TO LIGHT HAZARD OCCUPANCY REQUIREMENTS OF MFA 13.
33.3. PROVIDE FIRE TEST DATA AND RECORDS AND PERSONAL PRESERVED DEVELOPED UNDER FIRE FLOW CONDITIONS AS REQUIRED BY A.H.J., AUTHORITY HAVING JURISDICTION.
34. ADD NEW SPROKLER HEADS IN ACCORDANCE WITH MFA 63 ALL APPLICABLE CODES AND ORDINANCES TO COMPLETE THE NEW WORK. SYSTEM SHALL BE INSTALLED COMPLETE AND OPERATIONAL, INCLUDING WATER FLOW INDICATOR, CONNECTIONS TO EXISTING ALARM, DRAIN PIPING, IDENTIFICATION SIGNS, ETC.
35. WORK SHALL BE PERFORMED BY A QUALIFIED FIRE SPROKLER INSTALLER WITH A MINIMUM OF FIVE (5) YEARS EXPERIENCE IN FIRE INSTALLATIONS.
36. COORDINATE ALL WORK WITH ALL OTHER TRADES PRIOR TO AND DURING INSTALLATION.
37. PROVIDE AN EXTRA STOCK OF SIX (6) SPROKLER HEADS, THREE (3) OF EACH TYPE, AND A SPROKLER WRENCH. SPROKLER HEADS SHALL MATCH EXISTING IN ADJACENT AREAS.

UTILITY NOTES

- 1. ALL COORDINATION WITH NTA, NAVAJO TRAIL UTILITY AUTHORITY SHALL BE FOLLOWED THROUGHOUT THIS PROJECT. GOOD COOPERATION WITH NTA DESIGN AND CONSTRUCTION STANDARDS AND UTILITY REQUIREMENTS ARE MET. IT IS THE RESPONSIBILITY OF THE CONTRACTOR TO COORDINATE WITH THE LATEST EDITION OF IEEE, NATIONAL ELECTRICAL CODE, ANY UNDERGROUND UTILITIES, AND METHODS OF INSTALLATION AND INSPECTION) SHALL COMPLY WITH SPECIFICATIONS AS NOTED IN THE NTA CONSTRUCTION DRAWINGS MANUAL.
A. ALL EXISTING HAZARDOUS UTILITIES ARE TO REMAIN IN PLACE AND ARE TO BE PROTECTED DURING DEMOLITION AND CONSTRUCTION UNLESS OTHERWISE NOTED.
B. IF ANY UTILITY LINES, PIPELINES, OR ANY UNDERGROUND UTILITY LINES ARE SHOWN ON THESE DRAWINGS, THEY ARE SHOWN IN AN APPROXIMATE MANNER ONLY, AND SUCH LINES MAY EXIST WITHOUT NON-RECORDED INFORMATION. IF ANY SUCH EXISTING LINES ARE SHOWN, THE LOCATION IS BASED UPON INFORMATION PROVIDED TO THE ENGINEER BY OTHERS, AND THE INFORMATION MAY BE INCOMPLETE. DELAYS OR COSTS MAY BE INCURRED BY THE TIME CONSTRUCTION COMMENCES. THE CONTRACTOR SHALL VERIFY THE LOCATION OF ANY UTILITY LINE, PIPELINE OR UNDERGROUND UTILITY LINE IN OR NEAR THE AREA OF THE WORK.
C. CONTRACTOR SHALL COORDINATE ELECTRICAL, WATER, AND COMMUNICATION SERVICES AND EXTENSIONS WITH LOCAL UTILITY SERVICE PROVIDERS.
D. THE CONTRACTOR SHALL NOTIFY ALL APPLICABLE UTILITY COMPANIES AT LEAST TWO (2) DAYS PRIOR TO ANY EXCAVATION OR ERECTION.
E. ALL UTILITY WORK SHALL FOLLOW NTA, NAVAJO TRAIL UTILITY AUTHORITY.
F. VERTICAL SEPARATION OF WATER AND SEWER LINES (INCLUDES SERVICE LINES):
F.A. WATER ABOVE SEWER: WHEN WATER LINES CROSS SEWER LINES, THE WATER LINES SHALL CROSS ABOVE THE SEWER LINE WITH A MINIMUM VERTICAL SEPARATION OF 12 INCHES (O.D. TO O.D.). IF NECESSARY, THE DEPTH OF DIRT FOR THE WATER LINE MAY BE REDUCED TO 36 INCHES (NOMINALLY) MINIMUMS) AT THE CROSSING TO MAINTAIN THE 12 INCH VERTICAL SEPARATION, WHEN THE LENGTH OF VERTICAL SEPARATION IS NOT POSSIBLE, THE WATER LINE IS NOT PERMITTED WITHIN 10 FEET OF CROSSING A SEWER LINE. SEWER ABOVE WATER: WHEN A WATER LINE MUST CROSS BELOW A SEWER LINE, THE MINIMUM VERTICAL SEPARATION BETWEEN THE LINES IS 18-INCHES MINIMUM. ALL TRENCHES SHALL BE COMPLETED TO PROVIDE ADEQUATE SUPPORT TO PREVENT SETTLING OF THE SEWER LINE AND DAMAGING THE WATER LINE.
F.C. ALL NEW WATER LINES SHALL BE NORMAL, P.V.C. OR PE WATER DISTRIBUTION PIPE WITH A 2-POUR (DRINKING) PIPE SECTION CENTERED ON THE SEWER CROSSING. NO ARCHES OF NEW WATER LINE CONSTRUCTION SHALL BE PERMITTED WITHIN 5 FEET OF CROSSING A SEWER LINE. WHERE IT IS DESIRABLE TO HAVE CROSSINGS PERPENDICULAR, NEW WATER LINE CENTERED ON THE CROSSING) MAY CROSS UNDER A SEWER LINE AT A MAXIMUM OF 24 DEGREES FROM PERPENDICULAR.
F.D. THE NEW SEWER LINE SHALL BE CASTLE IRON PIPE WITH GASKET JOINTS, OR APPROVED EQUIV. WITH AN 18-FOOT SECTION CENTERED ON THE CROSSING. NO JOINTS IN THE NEW SEWER LINE CONSTRUCTION SHALL BE PERMITTED WITHIN 5 FEET OF CROSSING WATER LINE.

PROJECT GENERAL NOTES

- ELECTRICAL
A. IT IS THE RESPONSIBILITY OF THE CONTRACTOR TO MAINTAIN THESE LINES WITH THE ENTIRE PROJECT PRIOR TO GO. THIS IS TO ALLOW FOR A COMPLETE AND ACCURATE RECORD PERTAINING TO SCOPE INDICATED ON THE DESIGN DRAWINGS AND SPECIFICATIONS. THE CONTRACTOR SHALL BE RESPONSIBLE TO THE SCOPE OF WORK INDICATED, WHAT THE CONTRACTOR'S FUNCTIONS ARE OR ANY OTHER ISSUE RELATED TO THE PROJECT ITSELF SHALL BE IDENTIFIED DURING THE BID PERIOD AND CLEARANCE TO THE OWNER FOR CLARIFICATION PRIOR TO AWARD OF CONTRACT.
D. IT WILL BE THE CONTRACTOR'S OBLIGATION TO INCLUDE IN THEIR BID THE COSTS FOR INSTALLATION OF ALUMINUM BRACKETS, CONSULT SURVEY, GUY WIRE COVER PLATES, COORDINATION WITH OTHER TRADES, AND OTHER MISCELLANEOUS ITEMS THAT PERTAIN TO THE SCOPE OF WORK INDICATED.
C. ALL ELECTRICAL WORK SHALL BE IN ACCORDANCE WITH THE LATEST EDITION OF THE NATIONAL ELECTRICAL CODE (NEC).
D. LOCATIONS OF ELECTRICAL EQUIPMENT AND ALL OTHER DEVICES SHOWN ON THE PLANS ARE APPROXIMATE AND SHALL BE FIELD VERIFIED. IT IS THE RESPONSIBILITY OF THE CONTRACTOR TO COORDINATE WITH ALL TRADES FOR EXACT LOCATION OF OTHER EQUIPMENT THAT REQUIRE ELECTRICAL CONNECTIONS.
E. ALL CONDUIT ROUTINGS SHOWN ON THE PLAN DRAWINGS ARE APPROXIMATE. EXACT ROUTINGS AND LOCATION OF CONDUITS SHALL BE COORDINATED IN THE FIELD AND INSTALLED AS FIELD CONDITIONS ALLOW.
F. ALL HOME RUN CONDUITS SHALL BE 1/2" EMT CONDUIT, WITH #12 THRU COVER INSIDE BRACKETS, UNLESS OTHERWISE NOTED.
G. THE MOUNTING HEIGHTS INDICATED ON THE DRAWINGS ARE APPROXIMATE. IT IS THE RESPONSIBILITY OF THE CONTRACTOR TO COORDINATE WITH THE OTHER TRADES AND REVIEW WITH THE ARCHITECTURAL INFORMATION FOR EXACT HEIGHTS OF DEVICES PRIOR TO ELECTRICAL INSTALLATION. UNLESS OTHERWISE NOTED, THIS ALSO PERTAINS TO LOCATIONS OF WALL BOXES, RECESSED, TEST, AND CONTROL, ETC.
H. SHOULD CONTRACTOR AT ANY TIME NOTICE THAT THE ACTUAL FIELD CONDITIONS DO NOT CORRESPOND TO THE INFORMATION INDICATED ON THE DRAWINGS, IT IS THE RESPONSIBILITY OF THE CONTRACTOR TO NOTIFY THE ARCHITECT FOR CLARIFICATION AND DISCRETION PRIOR TO COMMENCING WORK. THE WORK SHALL BE STOPPED IMMEDIATELY UNTIL THE ARCHITECT'S DECISIONS SHALL BE NOTED ON THE DRAWINGS OR BY THE CONTRACTOR.
I. THE CONTRACTOR SHALL COORDINATE ALL WORK WITH OTHER TRADES PRIOR TO COMMENCING WORK.
J. ALL PIPING SHALL BE CONCEALED WHERE POSSIBLE, ALL EXPOSED PIPING, WHERE CONCEALMENT IS NOT POSSIBLE SHALL BE INSTALLED IN A NEAT AND PROFESSIONAL MANNER.
MECHANICAL
L. ALL DUCT SIZES SHOWN ARE INSIDE FREE AREA DIMENSIONS. INSTALL DUCTWORK IN ATTIC SPACE AND ROUTED IN BETWEEN JOIST AND IN JOIST WEEDS. SUPPORT FROM TOP CHORD OF TRUSS. PROVIDE SUFFICIENT CLEARANCE FOR INSULATION THICKNESS.
M. PROVIDE ALL NECESSARY FITTINGS FOR RISERS AND OFFSETS IN DUCTWORK (REQUIRED FOR PROPER INSTALLATION WHETHER OR NOT SHOWN ON DRAWINGS).
N. ALL 90-DEGREE ELBOWS SHALL BE PROVIDED WITH DOUBLE TRACK TURNING VANES.
O. WALL MOUNTED THERMOSTATS SHALL BE MOUNTED AT ABOVE FINISHED FLOOR, UNLESS OTHERWISE NOTED.
P. ALL DUCT OFFSET SPACES SHALL BE INSULATED WITH 4200000 R-6 EXTERNAL INSULATION WRAP.
Q. PROVIDE EQUIPMENT WITH ALL REQUIRED SERVICE AND OPERATIONAL CLEARANCES (INCLUDING ALL REQUIRED CLEARANCES TO COMBUSTIBLES) (WHERE APPLICABLE) AND ALL CLEARANCES REQUIRED BY NEC ARTICLE 110. COORDINATE WORK WITH OTHER TRADES TO AVOID CONFLICTS.
ELECTRICAL
D. NO WATER PIPING SHALL BE LOCATED IN OUTSIDE WALLS, UNLESS SHOWN TO BE AND THEN PIPING TO BE INSULATED AND LOCATED AS CLOSE AS POSSIBLE TO INSIDE OF WALL CAVITY WITH ADDITIONAL INSULATION BETWEEN PIPING AND EXTERIOR OF WALL.
7. ALL PLUMBING FITTINGS WITH THE EXCEPTION OF SHOWN SHALL HAVE GASKET VALVES TO ALLOW FOR MAINTENANCE TO INDIVIDUAL FITTINGS WITHOUT SHUTTING WATER OFF.
U. ALL PLUMBING FITTINGS SHALL BE PROVIDED WITH ANGLE WALL STOPS ON THE WATER LINES, AND P-TRAPS AND VALVEES ON THE WATER OF ANY WALL MOUNTED PLUMBING FITTINGS.
V. REFER TO ARCHITECTURAL DRAWINGS FOR MOUNTING HEIGHTS OF PIPING.
W. ALL GUY WIRE PIPING AND SEWER VENT PIPING SHALL BE PVC. PVC PIPING SHALL BE INSTALLED PER CURRENT ASTM STANDARD PRACTICE FOR INSTALLATION OF THROU-ROOF PIPING FOR CONDENS AND OTHER GRAVITY-FLOW APPLICATIONS.
X. ALL DRAWINGS SHALL BE VALVED AND ALL VALVES SHALL HAVE UNIONS ADJACENT. ACCESS PANELS AND DOORS SHALL BE FURNISHED TO GENERAL CONTRACTOR FOR INSTALLATION AND ACCESS TO VALVES WHERE REQUIRED. LOCATE ADDITIONAL VALVES AS SHOWN ON DRAWINGS. SEE SPECIFICATIONS FOR ACCESS DOOR REQUIREMENTS.
Y. ALL PIPING SHALL FIT TO DRAWN AND CONTRACTOR SHALL PROVIDE VALVING FOR SYSTEM DRAINAGE.
Z. DOMESTIC WATER SHALL BE ROUTED THROUGHOUT BUILDING ABOVE CEILING AND DOWN IN WALLS OR CHASE, SERVING PLUMBING FIXTURES WITH THE USE OF COPPER PIPING SHALL HAVE JACKETED INSULATION AND LABELED.
A. ALL WORK PROVIDED BY THE CONTRACTOR SHALL HAVE A WARRANTY PERIOD OF ONE YEAR.
AD. PLUMBING CONTRACTOR SHALL REFER TO CIVIL PLANS PRIOR TO PIPING INSTALLATION FOR ALL SERVICE UTILITIES FOR POINT OF CONNECTION, ROUTING AND SERVICE ENTRANCE.

NAVAJO NATION BATHROOM ADDITIONS
NAVAJO NATION
CONSTRUCTION DOCUMENTS
OWNER:
NAVAJO ENG & CONSTRUCTION AUTHORITY

DESIGNER'S DESIGN STUDIO + ARCHITECTURE, LLC
8008 Pecos Avenue
Albuquerque, NM 87110
Tel: 505.226.2565
Fax: 505.226.2560
CONSULTANT INFO & LOGO
QAE
809 Ortiz Drive SE - Albuquerque, NM 87108
P: 505.333.0800 or 505.333.8171
www.qae.com



Table with columns: REV, DATE, DESCRIPTION. Row 1: 0, 8-18-2020, MEP Drawing Set

PROJECT NUMBER: M3-38
DRAWING FILE:
DRAWN BY: QA
CHECKED BY: QA
COPYRIGHT 2018 Ingenuity Design Studio + Architecture, LLC

SHEET TITLE
OUTLINE SPECIFICATIONS & PROJECT NOTES

SHEET NUMBER
MEP001
Copies: 0 of 0

NAVAJO NATION BATHROOM ADDITIONS
 NAVAJO NATION
 CONSTRUCTION DOCUMENTS
 OWNER: NAVAJO ENG & CONSTRUCTION AUTHORITY

GENIUS DESIGN STUDIO + ARCHITECTURE, LLC
 8003 Peachyville Circle NE Albuquerque, NM 87110
 Tel 505.228.2556 Fax 505.228.2556

CONSULTANT INFO & LOGO
QAE
 1401 Ortiz Drive SE - Albuquerque, NM 87108
 T 505.338.8900 • F 505.338.8771
 www.qaenm.com



CONSULTANT

MARK	DATE	DESCRIPTION
0	0-10-2020	MCP Drawing Set

PROJECT NUMBER: M101-SB
 DRAWING FILE: R04
 CHECKED BY: R04
 COPYRIGHT © 2019 Ingenium Design Studio + Architecture, LLC

SHEET TITLE
MECHANICAL FLOOR PLAN

SHEET NUMBER
M101
 Sequence of 0

01/15/2020 4:35:30 PM

GENERAL NOTES

A. REFER TO SHEET M201 FOR OUTLINE SPECIFICATIONS, PROJECT GENERAL NOTES AND UTILITY NOTES.

KEYED NOTES

1. LP GAS FRIED WALL MOUNTED UNIT HEATER, SEE SHEET M091, EQUIPMENT SCHEDULE & DETAILS.
2. MAINTAIN MANUFACTURER'S INSTALLATION CLEARANCE REQUIREMENTS.
3. INSTALL MINIMUM (2) 6" CONCRETE AIR DUCT, TERMINATE WITH BOSS/ANCHOR AND FLECT BOLT. REFER TO DWG M091, CA DUCT DETAIL, TYPICAL.
4. IF FLUE THRU ROOF FROM ATMOSPHERIC WATER HEATER, OFFSET FLUE AS NECESSARY TO AVOID CONFLICTS WITH STRUCTURE OR OTHER TRADES.
5. OFFSET FLUE WITH MINIMUM DISTANCE OF 8" FROM CA, CONCRETE AIR DUCTS.
6. EXHA ELECTRIC WATER HEATER. REFER TO SHEET M091, EQUIPMENT SCHEDULE.
7. EXHA ELECTRIC UNIT HEATER. REFER TO SHEET M091, EQUIPMENT SCHEDULE.

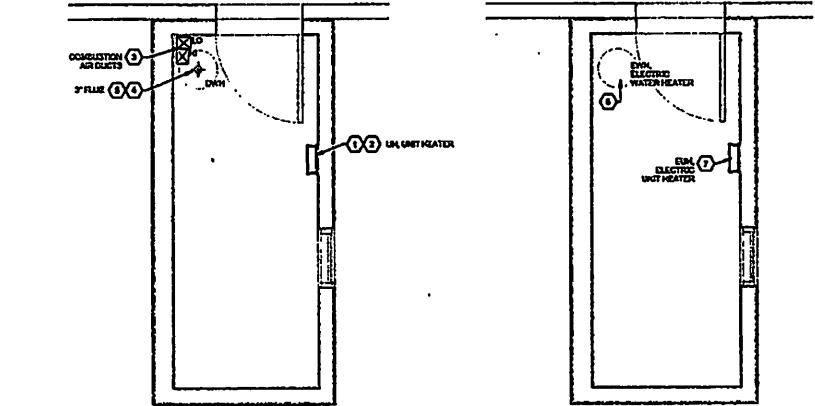
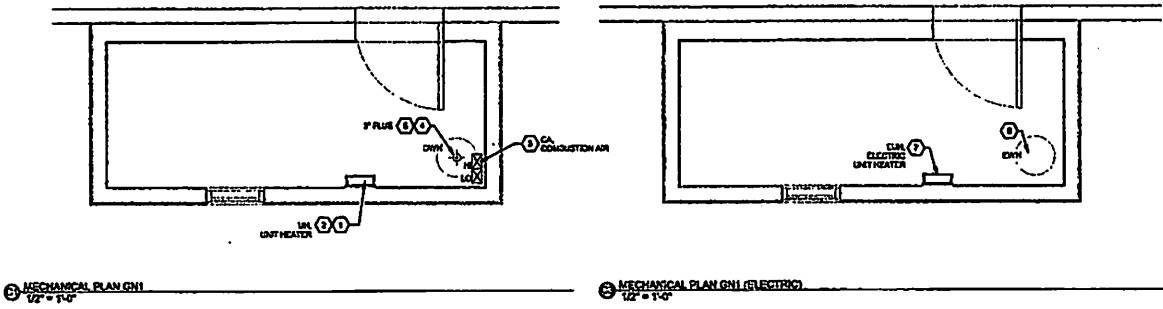

DOMESTIC WATER HEATER SCHEDULE (LP GAS)

SYMBOL	MANUFACTURER AND MODEL	TYPE	SPACE	CURSET TEMP (°F)	DRY VOLUME (GALLONS)	BTU INPUT (BTU)	RECOVERY @ 80°F	RECOVERY EFFICIENCY	APPROX. TYPICAL EAS1
DWH	BEHRM PERFORMANCE MODEL NO. 6700000001	LP GAS	DOMESTIC HOT WATER	110	38	30	<1	88	110

NOTES:
 1. CONTRACTOR SHALL PROVIDE A COMPLETE OPERATING SYSTEM. PROVIDE WATER HEATER WITH INSULATED BLANKET.
 2. WATER HEATER WITH FOUR YEAR WARRANTY. CONDENSING. 80% EFFICIENCY AT 80°F.

DOMESTIC WATER HEATER SCHEDULE (ELECTRIC)

SYMBOL	MANUFACTURER AND MODEL	TYPE	SOURCE	ELECTRIC	RECOVERY @ 80°F	RECOVERY EFFICIENCY	APPROX. TYPICAL EAS1	
DWH	BEHRM PERFORMANCE MODEL NO. 6700000001	ELECTRIC	DOMESTIC HOT WATER	EXHA ELECTRIC	80%	19	21	80

NOTES:
 1. CONTRACTOR SHALL PROVIDE A COMPLETE OPERATING SYSTEM. PROVIDE WATER HEATER WITH INSULATION BLANKET.
 2. WATER HEATER WITH FOUR YEAR WARRANTY. CONDENSING. 80% EFFICIENCY AT 80°F.

UNIT WALL HEATER SCHEDULE (LP GAS)

SYMBOL	MANUFACTURER AND MODEL	TYPE	INSTALL STD	OPERATED PRESSURE	ORIFICE(S)	REQUIRED (2) ORIFICE RELIEF CONCRETE/MASS VENTILATION
UH	BEHRM OLD MODEL NO. 670001111001	LP GAS	EXHA	17" WC	27.1 X 0.75 X 0.75	TWO (2) 1/2" Ø ORIFICES SHALL BE INSTALLED. ONE ORIFICE TO BE ON EACH SIDE OF THE UNIT AND THE OTHER ORIFICE TO BE ABOVE FINISHED FLOOR.

NOTES:
 1. CONTRACTOR SHALL PROVIDE A COMPLETE OPERATING SYSTEM.
 2. MAINTAIN REQUIRED CLEARANCES FROM COMBUSTIBLES AND WALLS.
 3. UNIT WALL HEATER WITH ELECTRIC FLUE BLOWER. FLECTOR DETECTOR. 80% EFFICIENCY.

UNIT WALL HEATER SCHEDULE (ELECTRIC)

SYMBOL	MANUFACTURER AND MODEL	ELECTRIC	DRIVING	REMARKS
UH	BEHRM WALL HEATER MODEL NO. 670001111001	EXHA LP	EXHA	EXHA ELECTRIC UNIT HEATER. MAINTAIN MINIMUM CLEARANCES FROM COMBUSTIBLES AND WALLS. SWIFT SWITCH.

NOTES:
 1. CONTRACTOR SHALL PROVIDE A COMPLETE OPERATING SYSTEM.

C:\Users\hmf\Documents\MECA 150 Bathroom Additions_MCP_Visual\mcp_sbsb150.dwg

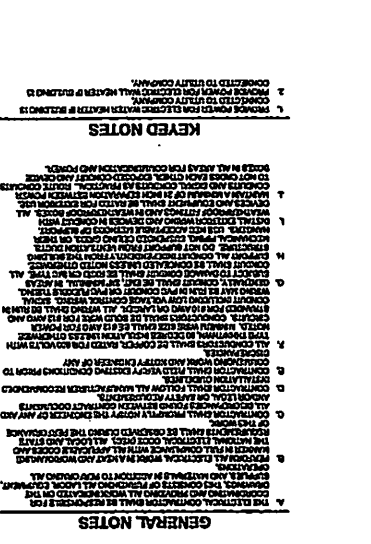
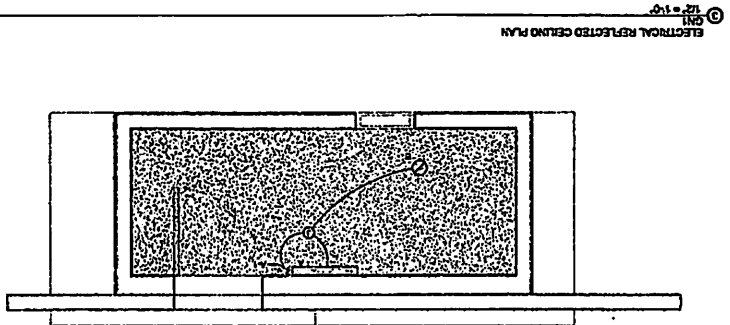
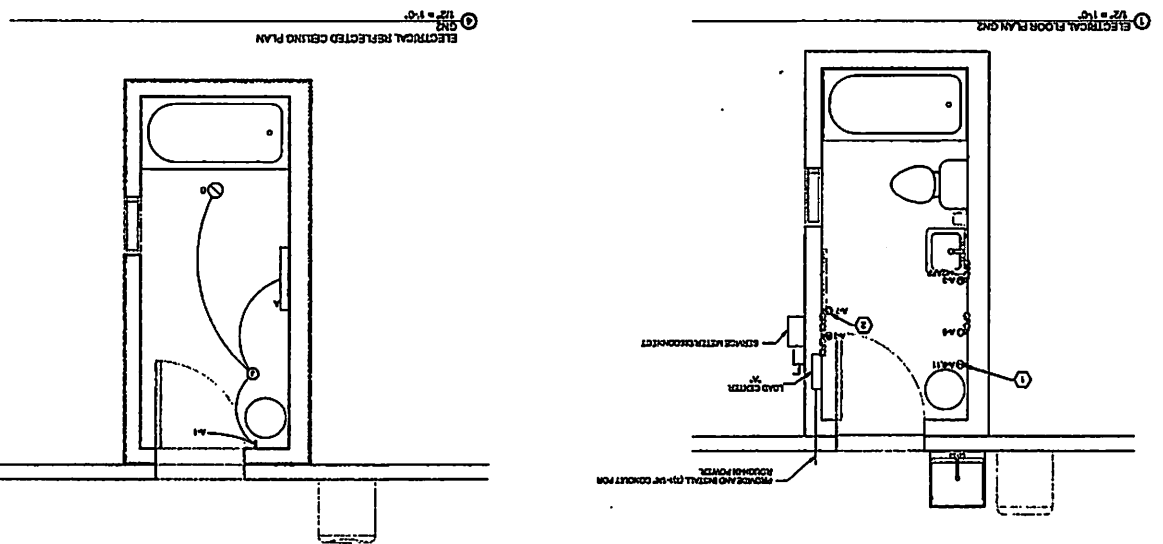
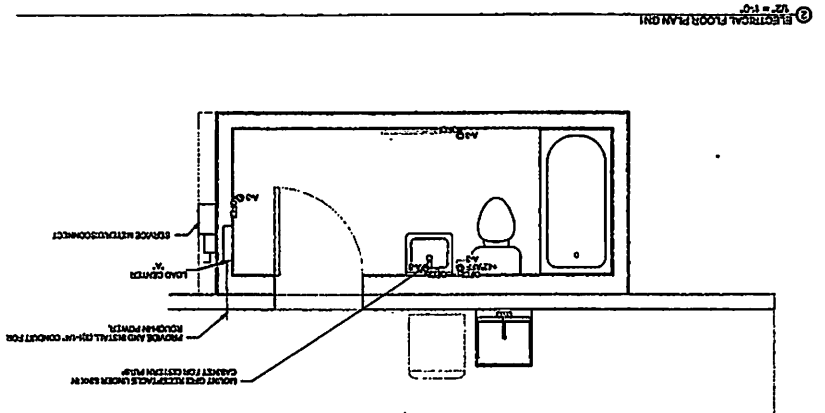

GENERAL NOTES

1. THE ELECTRICAL CONTRACTOR SHALL BE RESPONSIBLE FOR OBTAINING ALL NECESSARY PERMITS AND APPROVALS FROM THE LOCAL ELECTRICAL CODES AND REGULATORY AGENCIES.
2. ALL ELECTRICAL WORK SHALL BE IN ACCORDANCE WITH THE NATIONAL ELECTRICAL CODE (NEC) AND ALL APPLICABLE LOCAL CODES.
3. THE CONTRACTOR SHALL BE RESPONSIBLE FOR OBTAINING ALL NECESSARY PERMITS AND APPROVALS FROM THE LOCAL ELECTRICAL CODES AND REGULATORY AGENCIES.
4. ALL ELECTRICAL WORK SHALL BE IN ACCORDANCE WITH THE NATIONAL ELECTRICAL CODE (NEC) AND ALL APPLICABLE LOCAL CODES.
5. THE CONTRACTOR SHALL BE RESPONSIBLE FOR OBTAINING ALL NECESSARY PERMITS AND APPROVALS FROM THE LOCAL ELECTRICAL CODES AND REGULATORY AGENCIES.
6. ALL ELECTRICAL WORK SHALL BE IN ACCORDANCE WITH THE NATIONAL ELECTRICAL CODE (NEC) AND ALL APPLICABLE LOCAL CODES.
7. THE CONTRACTOR SHALL BE RESPONSIBLE FOR OBTAINING ALL NECESSARY PERMITS AND APPROVALS FROM THE LOCAL ELECTRICAL CODES AND REGULATORY AGENCIES.
8. ALL ELECTRICAL WORK SHALL BE IN ACCORDANCE WITH THE NATIONAL ELECTRICAL CODE (NEC) AND ALL APPLICABLE LOCAL CODES.
9. THE CONTRACTOR SHALL BE RESPONSIBLE FOR OBTAINING ALL NECESSARY PERMITS AND APPROVALS FROM THE LOCAL ELECTRICAL CODES AND REGULATORY AGENCIES.
10. ALL ELECTRICAL WORK SHALL BE IN ACCORDANCE WITH THE NATIONAL ELECTRICAL CODE (NEC) AND ALL APPLICABLE LOCAL CODES.

KEYED NOTES

1. PROVIDE AND RETAIL GFI-RC CONDUIT FOR ROUGH-IN POWER.
2. CONNECT TO EXISTING RUP.
3. CONNECT TO EXISTING RUP.
4. CONNECT TO EXISTING RUP.
5. CONNECT TO EXISTING RUP.
6. CONNECT TO EXISTING RUP.
7. CONNECT TO EXISTING RUP.
8. CONNECT TO EXISTING RUP.
9. CONNECT TO EXISTING RUP.
10. CONNECT TO EXISTING RUP.

SHEET NUMBER
E101

ELECTRICAL FLOOR PLANS

PROJECT NUMBER: 130
DRAWING FILE: 130
CHECKED BY: JES
DATE: 12/24/2020

NO.	DATE	DESCRIPTION
1	12/24/2020	ISSUED FOR PERMITS

CONSULTANT: **ONE CONSULTANT INFO & LOGO**

ARCHITECTURE, INC. 6008 Parkway Blvd. Suite 100, Jacksonville, FL 32217
Tel: 904.228.2200 Fax: 904.228.2205

OWNER: NAVAJO NATION CONSTRUCTION AUTHORITY

NAVAJO NATION BATHROOM ADDITIONS
CONSTRUCTION DOCUMENTS

SHEET NUMBER
E101

GENERAL NOTES

- A. THE ELECTRICAL CONTRACTOR SHALL BE RESPONSIBLE FOR COORDINATING AND PROVIDING ALL WORK INDICATED ON THE DRAWINGS. THIS INCLUDES THE PURCHASING ALL LABOR, EQUIPMENT, SUPPLIES, AND MATERIALS IN ADDITION TO PERFORMING ALL OPERATIONS.
- B. PROVIDE ALL ELECTRICAL WORK IN A NEAT AND WORKMANLIKE MANNER IN FULL COMPLIANCE WITH ALL APPLICABLE CODES AND THE NATIONAL ELECTRICAL CODE (NEC). ALL LOCAL AND STATE REQUIREMENTS SHALL BE OBSERVED DURING THE PROGRESS OF THIS WORK.
- C. CONTRACTOR SHALL PROMPTLY NOTIFY THE ENGINEER OF ANY AND ALL DISCREPANCIES FOUND BETWEEN CONTRACT REQUIREMENTS AND/OR LOCAL OR STATE REQUIREMENTS.
- D. CONTRACTOR SHALL FOLLOW ALL MANUFACTURER RECOMMENDED INSTALLATION GUIDELINES.
- E. CONTRACTOR SHALL FIELD VERIFY EXISTING CONDITIONS PRIOR TO COMMENCING WORK AND NOTIFY ENGINEER OF ANY DISCREPANCIES.
- F. ALL CONDUCTORS SHALL BE COPPER RATED FOR 60 VOLTS WITH TYPE THHN/THWN, TO EXCEED 90% AMPS UNLESS OTHERWISE NOTED. NON-FLEXIBLE CORD SHALL BE #12 AWG FOR POWER CONDUITS. CONDUCTORS SHALL BE SOLID BARE FOR #14 AWG AND STRANDED FOR #10 AWG OR LARGER. ALL WIRING SHALL BE NEATLY CONSULT INCLUDING LOW VOLTAGE CONTROL WIRING. CONDUIT WIRING SHALL BE RUN IN PVC CONDUIT OR FIBERGLASS TUBING.
- G. GENERALLY, CONDUIT SHALL BE OUT, IMP. UNLESS IN AREAS COLLECT TO DAMAGE CONDUIT SHALL BE PROOF DRUM TYPE. ALL CONDUIT SHALL BE CONCEALED UNLESS NOTED OTHERWISE.
- H. SUPPORT ALL CONDUIT AND CABLES PROPERLY FROM THE BUILDING STRUCTURE. DO NOT SUPPORT FROM VIBRATION SLACKS, MECHANICAL WIRING, SUSPENDED CEILING GRID, OR OTHER HANGERS. USE MOST ACCEPTABLE METHOD OF SUPPORT.
- I. INSTALL EXTERIOR WIRING AND DEVICES IN CONDUIT WITH WEATHERPROOF FITTINGS AND IN WEATHERPROOF BOXES. ALL DEVICES AND EQUIPMENT SHALL BE RATED FOR EXTERIOR USE.
- J. MAINTAIN A SEPARATION OF 1/4 INCH SEPARATION BETWEEN POWER CONDUITS AND DATA CONDUITS AS PRACTICAL. ROUTE CONDUITS TO NOT CROSS EACH OTHER. EXPOSED CONDUIT AND DEVICE COVERS IN ALL AREAS FOR COMMUNICATION AND POWER.

LUMINAIRE SCHEDULE						
1. ABBREVIATIONS: C=CEILING; P=PENDANT; R=RECESSED; S=DOWN ACE; T=TRACK; W=WALL; A=AS INDICATED; CB=CONDUIT IN DUCT.						
2. CIRCLE NUMBERED PREFIX IN LAMP COLUMN INDICATES NUMBER OF LAMPS IN LUMINAIRE (e.g., (7) F27S/P3/24/00).						
3. LAMPS ARE SPECIFIED BY TYPE LAMP IN CIRCLE, NOT AWG CODE NUMBER. LAMPS LISTED ARE COMMON SYLVANIA UNLESS OTHERWISE NOTED.						
4. MANUFACTURER AND CATALOG NUMBER LISTED ARE PRIMARY SPECIFICATION AND INDICATE DESIGN INTENT. ALTERNATE MANUFACTURERS ARE GIVEN BY NAME ONLY.						
5. *** INDICATES MANUFACTURER'S CATALOG NUMBER LISTING FOR CEILING TYPE MOUNTING OPTION. CONTRACTOR SHALL COORDINATE WITH FINAL ARCHITECTURAL REP PRIOR TO ORDERING.						
6. FIRST NAMED MANUFACTURER AND CATALOG NUMBER CONSTITUTE BASIS OF DESIGN. ALTERNATE MANUFACTURERS SUBMITTED MUST MEET CONSTRUCTION, OPERABILITY, PHOTOGRAPHIC AND AESTHETIC CRITERIA SET FORTH BY BASIS OF DESIGN PROVIDED INFORMATION.						
TYPE	MANUFACTURERS	ALTERNATE NUMBER	DESCRIPTION	MTG.	LAMPING	VOLTS / WATTS
A	Horse Decorative Collection Model Ralund 22307	APPROVED EQUAL	2 Wtd Vlsby, 3000K, 730 Lumens, damp rated.	R	INTEGRAL LED	120V / 12
D	LED Downlight RLS07WHS3GR Recessed Can Housing: H70CT	APPROVED EQUAL	0" Recessed can, 3000K, 0 to 1 Layers, wet location listing.	R	INTEGRAL LED	120V / 0

NEW LOAD CENTER 'A' TO PV SYSTEM									
VOLTAGE:	120V	FRAME:	100A	MIN AIC RATING:	22,000				
PHASE:	1 PHASE	MAKE:	ILCO	CIRCUITS:	12				
WIRE:	3 WIRE	ENCLOSURE:	NEMA 1	MOUNTING:	RECESSED				
FEED:	TOP	LOCATION:	INTROR						
CKT NO	BKR RTNG	LOAD DESCRIPTION	VA	CONNECTED VA LOAD		VA	LOAD DESCRIPTION	BKR RTNG	CKT NO
				A	B				
1	20A1	RESTROOM LIGHTING	40	40	0	0	FUTURE RECEPTACLES		2
3	20A1	RESTROOM RECEPTACLES/WALL HEATER	378		378	0	FUTURE LIGHTS		4
5	20A1	CISTERN PUMP	684	684		0	FUTURE FRIDGE		6
7		Space			0	0	Space		8
9		Space			0	0	Space		10
11		Space			0	0	Space		12
CONNECTED LOAD (VA) PER PHASE			724	378	1102	TOTAL CONNECTED LOAD (VA)			
					6.2	TOTAL CONNECTED LOAD (AMPS)			

NEW LOAD CENTER 'A' TO UTILITY									
VOLTAGE:	120/240V	FRAME:	100A	MIN AIC RATING:	22,000				
PHASE:	1 PHASE	MAKE:	ILCO	CIRCUITS:	12				
WIRE:	3 WIRE	ENCLOSURE:	NEMA 1	MOUNTING:	RECESSED				
FEED:	TOP	LOCATION:	INTROR						
CKT NO	BKR RTNG	LOAD DESCRIPTION	VA	CONNECTED VA LOAD		VA	LOAD DESCRIPTION	BKR RTNG	CKT NO
				A	B				
1	20A1	RESTROOM LIGHTING	40	40	0	0	FUTURE RECEPTACLES		2
3	20A1	RESTROOM RECEPTACLES/WALL HEATER	378		378	0	FUTURE LIGHTS		4
5	20A1	CISTERN PUMP	684	684		0	FUTURE FRIDGE		6
7	20A1	ELECTRIC WALL HEATER (OPTIONAL)	1500		1500	0	Space		8
9		Space			4500	0	Space		10
11	50A2	ELECTRIC WATER HEATER (OPTIONAL)	4500		4500	0	Space		12
CONNECTED LOAD (VA) PER PHASE			524	638	1162	TOTAL CONNECTED LOAD (VA)			
					48.3	TOTAL CONNECTED LOAD (AMPS)			

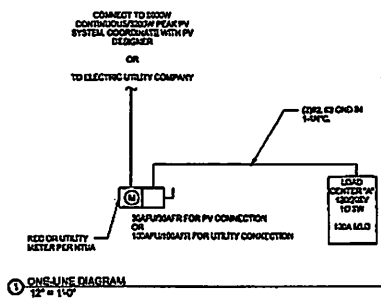

ONE-LINE DIAGRAM 12-1-10

NAVAJO NATION BATHROOM ADDITIONS
NAVAJO NATION
CONSTRUCTION DOCUMENTS
 OWNER: NAVAJO ENG & CONSTRUCTION AUTHORITY

INDIGENOUS DESIGN STUDIO + ARCHITECTURE, LLC
 8006 Pennsylvania Circle NE Albuquerque, NM 87110
 Tel: 505.226.2559 Fax: 505.226.2560

CONSULTANT INFO & LOGO

 1400 Cort Drive SE • Albuquerque, NM 87105
 T: 505.243.0392 • F: 505.243.1071
 www.qaeconsulting.com

CONSULTANT

MARK	DATE	DESCRIPTION
0	9-18-2020	M3P Drawing Set

PROJECT NUMBER: M3-38
 DRAWING FILE: WJ
 DRAWN BY: JCA
 CHECKED BY:
 COPYRIGHT 2018 Indigenous Design Studio + Architects, LLC

SHEET TITLE
ELECTRICAL SCHEDULES & ONLINE DIAGRAM

SHEET NUMBER
E601
 Sequence of 6

C:\Users\jacob\Documents\MECA 150 Bathroom Additions_MEP_V1200_rvt\meca150\DWG

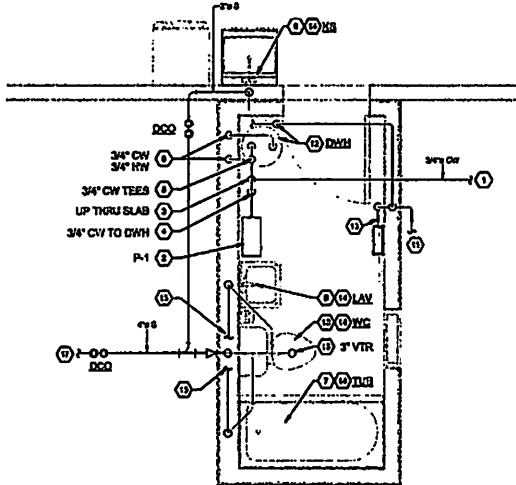

12 PLUMBING PLAN GN2
1/2" = 1'-0"

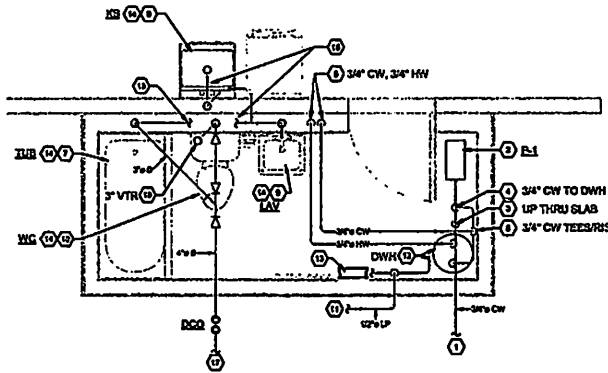

13 PLUMBING PLAN GN1
1/2" = 1'-0"

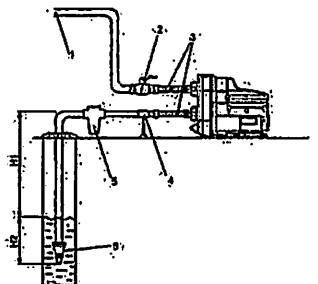

- Pos. Description**
- 1 TO WATER HEATER
 - 2 COLLARING VALVE
 - 3 FLEXIBLE HOSES
 - 4 PIPE SUPPORT
 - 5 INLET FILTER. WATER MAY CONTAIN SAND, GRAVEL OR OTHER DEBRIS. RECOMMENDED TO INSTALL FILTER ON DAILEY SIDE TO PROTECT PUMP AND INSTALLATION WARRANTY.
 - 6 FOOT VALVE WITH STRAINER (RECOMMENDED)
 - 11 MAXIMUM SUCTION LIFT IS 25 FEET
 - 12 INLET PIPE MUST BE SCHEDULED AT LEAST 1/2" EWT

1 SUCTON FROM WELL
3/16" = 1'-0"

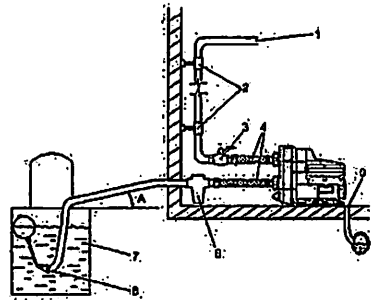

- Pos. Description**
- 1 TO WATER HEATER
 - 2 PIPE HANGERS
 - 3 ISOLATING VALVE
 - 4 FLEXIBLE HOSES
 - 5 DRAIN TO CENTER
 - 6 INLET FILTER. WATER MAY CONTAIN SAND, GRAVEL OR OTHER DEBRIS. RECOMMENDED TO INSTALL FILTER ON DAILEY SIDE TO PROTECT PUMP AND INSTALLATION WARRANTY.
 - 7 FRESH WATER TANK
 - 8 FOOT VALVE WITH STRAINER (RECOMMENDED)
 - A MINIMUM 4 DEGREE INCLINATION (SLOPE)

2 SUCTON FROM FRESH WATER TANK
3/16" = 1'-0"

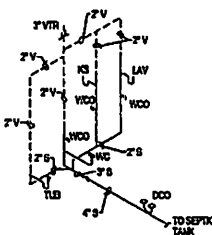

GN1 - WASTE & VENT

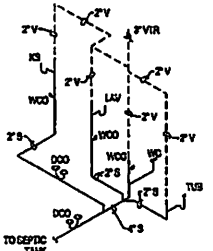

GN2 - WASTE & VENT

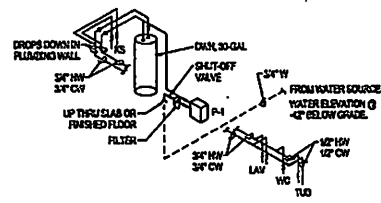

GN2 - WATER

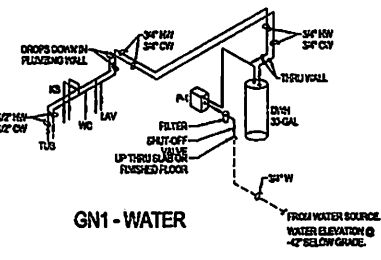

GN1 - WATER

GENERAL NOTES

A. REFER TO SHEET MECH FOR OUTLINE SPECIFICATIONS, PRODUCT GENERAL NOTES AND QUALITY NOTES.

KEYED NOTES

1. WATER SUPPLY PIPING AT -4\"/>
2. COUP-PROBING CHECKING PUMP. SECURE PUMP TO FRESH FLOOR AS RECOMMENDED BY MFG. INSTALL WITH RUBBER PAD TO DAMPEN VIBRATIONS. REFER TO MANUFACTURER'S INSTALLATION MANUAL.
3. 3/4\"/>
4. 3/4\"/>
5. 3/4\"/>
6. 3/4\"/>
7. PROVIDE 1/2\"/>
8. PROVIDE 1/2\"/>
9. PROVIDE 1/2\"/>
10. PROVIDE 1/2\"/>
11. 1/2\"/>
12. ROUTE 1/2\"/>
13. ROUTE 1/2\"/>
14. REFER TO SHEET MECH FOR WASTE AND VENT PIPE SIZE CONNECTIONS. PROVIDE WOOD WALL CLEANOUT TYPICAL.
15. SEE BMT MAIN WASTE PIPING FROM W.C. WATER CLOSET.
16. 2\"/>
17. ROUTE 2\"/>

NAVAJO NATION BATHROOM ADDITIONS
NAVAJO NATION
CONSTRUCTION DOCUMENTS
OWNER: NAVAJO NATION
CONSTRUCTION AUTHORITY

INDIGENOUS DESIGN STUDIO + ARCHITECTURE, LLC
6008 Peeterynina Circle NE
Albuquerque, NM 87110
Tel 505.220.3255
Fax 505.220.2965

CONSULTANT INFO & LOGO
QAE
1400 Ortiz Drive SE - Albuquerque, NM 87109
732.333.7000 • F 505.971.5771
www.qaefirm.com

MARK	DATE	DESCRIPTION
0	9-16-2020	MEP Drawing Set

PROJECT NUMBER: MD-38
DRAWING FILE:
DRAWN BY: HGA
CHECKED BY: BAO
COPYRIGHT © Indigenous Design Studio + Architecture, LLC.

SHEET TITLE
PLUMBING PLANS

SHEET NUMBER
P101
Deposits of 8
01/15/2020 4:39:37 PM

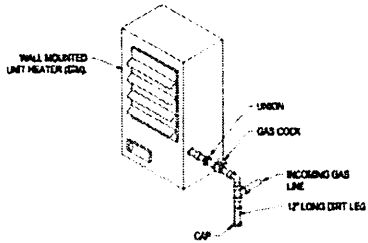

LP GAS FIRED UNIT HEATER DETAIL (SIMILAR)
SCALE: NTS

1
P-501

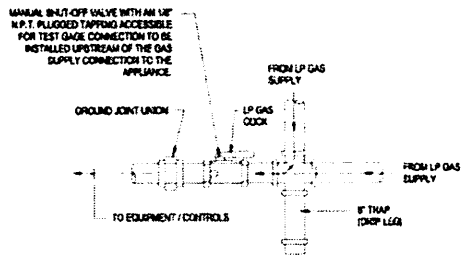

GAS CONNECTION TO EQUIPMENT DETAIL
SCALE: NTS

4
P-501

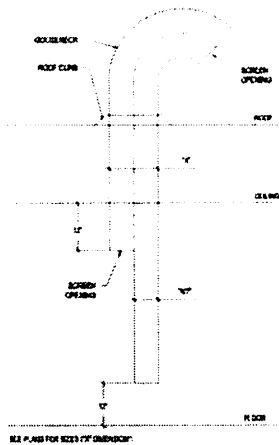

COMBUSTION AIR DUCT DETAIL (FOR LP GAS UNITS ONLY)
SCALE: NTS

1
P-501

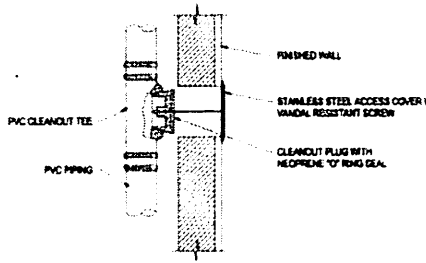

CLEANOUT THRU WALL DETAIL
SCALE: NTS

5
P-501

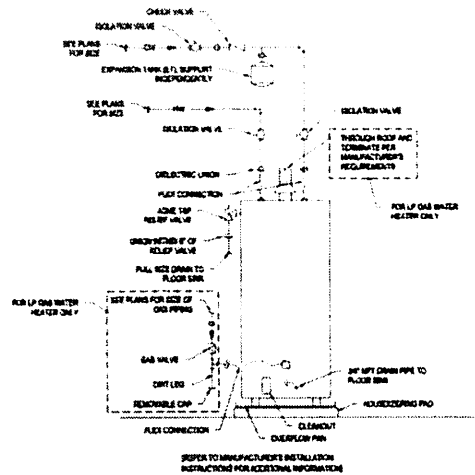

WATER HEATER PIPING DIAGRAM (LP GAS)
SCALE: NTS

2
P-501

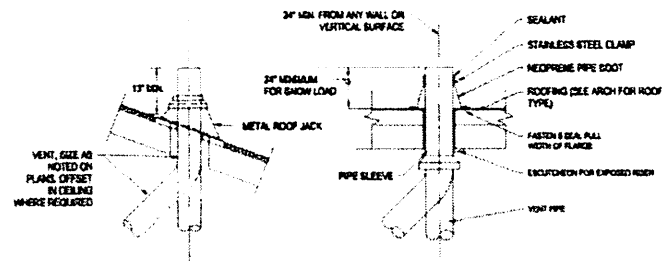

VTR VENT THROUGH ROOF DETAIL
SCALE: NTS

3
P-501

CISTERN PUMP SCHEDULE														
NO.	MANUFACTURER AND MODEL	SPRING	FLOW RATE (GPM)	WATER HEAD (FEET)	DISCHARGE HEAD (FEET)	TYPE	ELECTRICAL			DIMENSIONS			NOISE (D.B.)	
							VOLTS	PHASE	HERTZ	HP	H	W	D	
A-1	WILLOWBROOK SOLID STATE	NON-PORTABLE	17	143	107	107	120	1	60	1/2	11.0	11.0	11.0	10

ALTERNATE PRODUCT OPTION														
NO.	MANUFACTURER AND MODEL	SPRING	FLOW RATE (GPM)	WATER HEAD (FEET)	DISCHARGE HEAD (FEET)	TYPE	ELECTRICAL			DIMENSIONS			NOISE (D.B.)	
							VOLTS	PHASE	HERTZ	HP	H	W	D	
A-2 (OPTION A)	VALVE DIRECT	NON-PORTABLE	17.0	143	107	107	120	1	60	1/2	11.0	11.0	11.0	10
A-3 (OPTION B)	INVERTER SWALLOW	NON-PORTABLE	8	146	107	107	120	1	60	1/2	12.0	11.0	11.0	10

NOTES:
 1. SELECTED PUMP SHALL BE SELF-PRIMING.
 2. CONTRACTOR SHALL PROVIDE A COMPLETE SPRING SYSTEM. SELECTED PUMP SHALL HAVE INTERNAL MOTOR PROTECTION.
 3. PUMPING CAPACITY SHALL BE BASED ON THE PUMPING TO THE FLOOR COMPLIANCE THROUGH ROOFING WITH SEAL. PUMPING PVC COUPLING AND HOSE FILTER.

FIXING FIXTURE SCHEDULE									
NO.	DESCRIPTION	CONNECTIONS				REMARKS			
		DN	UP	SHRTE	HGT				
04	AMERICAN FLEXIBLE COUPLER (DUPLEX END)	1/2"		F	F	AMERICAN FLEXIBLE COUPLER (DUPLEX END) OF POLYMER COMPLETE WITH O-RING, RECEPTOR PLUG AND BRASS ACTION NUTS.			
05	AMERICAN FLEXIBLE COUPLER (WALL MOUNTED)	1/2"	1/2"	F	1/2"	AMERICAN FLEXIBLE COUPLER (WALL MOUNTED) COMPLETE WITH O-RING, RECEPTOR PLUG AND BRASS ACTION NUTS.			
06	1/2" CLASSIC 48 (BRASS) (WALL MOUNTED)	1/2"	1/2"	F	1/2"	1/2" x 1/2" CLASSIC 48 (BRASS) (WALL MOUNTED) COMPLETE WITH O-RING, RECEPTOR PLUG AND BRASS ACTION NUTS.			
07	1/2" CLASSIC 48 (BRASS) (WALL MOUNTED)	1/2"	1/2"	F	1/2"	1/2" x 1/2" CLASSIC 48 (BRASS) (WALL MOUNTED) COMPLETE WITH O-RING, RECEPTOR PLUG AND BRASS ACTION NUTS.			
08	ATCHER BRASS (WALL MOUNTED)	1/2"	1/2"	F	1/2"	1/2" CLASSIC 48 (BRASS) (WALL MOUNTED) COMPLETE WITH O-RING, RECEPTOR PLUG AND BRASS ACTION NUTS.			
09	1/2" CLASSIC 48 (BRASS) (WALL MOUNTED)	1/2"	1/2"	F	1/2"	1/2" x 1/2" CLASSIC 48 (BRASS) (WALL MOUNTED) COMPLETE WITH O-RING, RECEPTOR PLUG AND BRASS ACTION NUTS.			
10	1/2" CLASSIC 48 (BRASS) (WALL MOUNTED)	1/2"	1/2"	F	1/2"	1/2" x 1/2" CLASSIC 48 (BRASS) (WALL MOUNTED) COMPLETE WITH O-RING, RECEPTOR PLUG AND BRASS ACTION NUTS.			
11	1/2" CLASSIC 48 (BRASS) (WALL MOUNTED)	1/2"	1/2"	F	1/2"	1/2" x 1/2" CLASSIC 48 (BRASS) (WALL MOUNTED) COMPLETE WITH O-RING, RECEPTOR PLUG AND BRASS ACTION NUTS.			
12	1/2" CLASSIC 48 (BRASS) (WALL MOUNTED)	1/2"	1/2"	F	1/2"	1/2" x 1/2" CLASSIC 48 (BRASS) (WALL MOUNTED) COMPLETE WITH O-RING, RECEPTOR PLUG AND BRASS ACTION NUTS.			
13	1/2" CLASSIC 48 (BRASS) (WALL MOUNTED)	1/2"	1/2"	F	1/2"	1/2" x 1/2" CLASSIC 48 (BRASS) (WALL MOUNTED) COMPLETE WITH O-RING, RECEPTOR PLUG AND BRASS ACTION NUTS.			
14	1/2" CLASSIC 48 (BRASS) (WALL MOUNTED)	1/2"	1/2"	F	1/2"	1/2" x 1/2" CLASSIC 48 (BRASS) (WALL MOUNTED) COMPLETE WITH O-RING, RECEPTOR PLUG AND BRASS ACTION NUTS.			
15	1/2" CLASSIC 48 (BRASS) (WALL MOUNTED)	1/2"	1/2"	F	1/2"	1/2" x 1/2" CLASSIC 48 (BRASS) (WALL MOUNTED) COMPLETE WITH O-RING, RECEPTOR PLUG AND BRASS ACTION NUTS.			
16	1/2" CLASSIC 48 (BRASS) (WALL MOUNTED)	1/2"	1/2"	F	1/2"	1/2" x 1/2" CLASSIC 48 (BRASS) (WALL MOUNTED) COMPLETE WITH O-RING, RECEPTOR PLUG AND BRASS ACTION NUTS.			
17	1/2" CLASSIC 48 (BRASS) (WALL MOUNTED)	1/2"	1/2"	F	1/2"	1/2" x 1/2" CLASSIC 48 (BRASS) (WALL MOUNTED) COMPLETE WITH O-RING, RECEPTOR PLUG AND BRASS ACTION NUTS.			
18	1/2" CLASSIC 48 (BRASS) (WALL MOUNTED)	1/2"	1/2"	F	1/2"	1/2" x 1/2" CLASSIC 48 (BRASS) (WALL MOUNTED) COMPLETE WITH O-RING, RECEPTOR PLUG AND BRASS ACTION NUTS.			
19	1/2" CLASSIC 48 (BRASS) (WALL MOUNTED)	1/2"	1/2"	F	1/2"	1/2" x 1/2" CLASSIC 48 (BRASS) (WALL MOUNTED) COMPLETE WITH O-RING, RECEPTOR PLUG AND BRASS ACTION NUTS.			
20	1/2" CLASSIC 48 (BRASS) (WALL MOUNTED)	1/2"	1/2"	F	1/2"	1/2" x 1/2" CLASSIC 48 (BRASS) (WALL MOUNTED) COMPLETE WITH O-RING, RECEPTOR PLUG AND BRASS ACTION NUTS.			
21	1/2" CLASSIC 48 (BRASS) (WALL MOUNTED)	1/2"	1/2"	F	1/2"	1/2" x 1/2" CLASSIC 48 (BRASS) (WALL MOUNTED) COMPLETE WITH O-RING, RECEPTOR PLUG AND BRASS ACTION NUTS.			
22	1/2" CLASSIC 48 (BRASS) (WALL MOUNTED)	1/2"	1/2"	F	1/2"	1/2" x 1/2" CLASSIC 48 (BRASS) (WALL MOUNTED) COMPLETE WITH O-RING, RECEPTOR PLUG AND BRASS ACTION NUTS.			
23	1/2" CLASSIC 48 (BRASS) (WALL MOUNTED)	1/2"	1/2"	F	1/2"	1/2" x 1/2" CLASSIC 48 (BRASS) (WALL MOUNTED) COMPLETE WITH O-RING, RECEPTOR PLUG AND BRASS ACTION NUTS.			
24	1/2" CLASSIC 48 (BRASS) (WALL MOUNTED)	1/2"	1/2"	F	1/2"	1/2" x 1/2" CLASSIC 48 (BRASS) (WALL MOUNTED) COMPLETE WITH O-RING, RECEPTOR PLUG AND BRASS ACTION NUTS.			
25	1/2" CLASSIC 48 (BRASS) (WALL MOUNTED)	1/2"	1/2"	F	1/2"	1/2" x 1/2" CLASSIC 48 (BRASS) (WALL MOUNTED) COMPLETE WITH O-RING, RECEPTOR PLUG AND BRASS ACTION NUTS.			
26	1/2" CLASSIC 48 (BRASS) (WALL MOUNTED)	1/2"	1/2"	F	1/2"	1/2" x 1/2" CLASSIC 48 (BRASS) (WALL MOUNTED) COMPLETE WITH O-RING, RECEPTOR PLUG AND BRASS ACTION NUTS.			
27	1/2" CLASSIC 48 (BRASS) (WALL MOUNTED)	1/2"	1/2"	F	1/2"	1/2" x 1/2" CLASSIC 48 (BRASS) (WALL MOUNTED) COMPLETE WITH O-RING, RECEPTOR PLUG AND BRASS ACTION NUTS.			
28	1/2" CLASSIC 48 (BRASS) (WALL MOUNTED)	1/2"	1/2"	F	1/2"	1/2" x 1/2" CLASSIC 48 (BRASS) (WALL MOUNTED) COMPLETE WITH O-RING, RECEPTOR PLUG AND BRASS ACTION NUTS.			
29	1/2" CLASSIC 48 (BRASS) (WALL MOUNTED)	1/2"	1/2"	F	1/2"	1/2" x 1/2" CLASSIC 48 (BRASS) (WALL MOUNTED) COMPLETE WITH O-RING, RECEPTOR PLUG AND BRASS ACTION NUTS.			
30	1/2" CLASSIC 48 (BRASS) (WALL MOUNTED)	1/2"	1/2"	F	1/2"	1/2" x 1/2" CLASSIC 48 (BRASS) (WALL MOUNTED) COMPLETE WITH O-RING, RECEPTOR PLUG AND BRASS ACTION NUTS.			
31	1/2" CLASSIC 48 (BRASS) (WALL MOUNTED)	1/2"	1/2"	F	1/2"	1/2" x 1/2" CLASSIC 48 (BRASS) (WALL MOUNTED) COMPLETE WITH O-RING, RECEPTOR PLUG AND BRASS ACTION NUTS.			
32	1/2" CLASSIC 48 (BRASS) (WALL MOUNTED)	1/2"	1/2"	F	1/2"	1/2" x 1/2" CLASSIC 48 (BRASS) (WALL MOUNTED) COMPLETE WITH O-RING, RECEPTOR PLUG AND BRASS ACTION NUTS.			
33	1/2" CLASSIC 48 (BRASS) (WALL MOUNTED)	1/2"	1/2"	F	1/2"	1/2" x 1/2" CLASSIC 48 (BRASS) (WALL MOUNTED) COMPLETE WITH O-RING, RECEPTOR PLUG AND BRASS ACTION NUTS.			
34	1/2" CLASSIC 48 (BRASS) (WALL MOUNTED)	1/2"	1/2"	F	1/2"	1/2" x 1/2" CLASSIC 48 (BRASS) (WALL MOUNTED) COMPLETE WITH O-RING, RECEPTOR PLUG AND BRASS ACTION NUTS.			
35	1/2" CLASSIC 48 (BRASS) (WALL MOUNTED)	1/2"	1/2"	F	1/2"	1/2" x 1/2" CLASSIC 48 (BRASS) (WALL MOUNTED) COMPLETE WITH O-RING, RECEPTOR PLUG AND BRASS ACTION NUTS.			
36	1/2" CLASSIC 48 (BRASS) (WALL MOUNTED)	1/2"	1/2"	F	1/2"	1/2" x 1/2" CLASSIC 48 (BRASS) (WALL MOUNTED) COMPLETE WITH O-RING, RECEPTOR PLUG AND BRASS ACTION NUTS.			
37	1/2" CLASSIC 48 (BRASS) (WALL MOUNTED)	1/2"	1/2"	F	1/2"	1/2" x 1/2" CLASSIC 48 (BRASS) (WALL MOUNTED) COMPLETE WITH O-RING, RECEPTOR PLUG AND BRASS ACTION NUTS.			
38	1/2" CLASSIC 48 (BRASS) (WALL MOUNTED)	1/2"	1/2"	F	1/2"	1/2" x 1/2" CLASSIC 48 (BRASS) (WALL MOUNTED) COMPLETE WITH O-RING, RECEPTOR PLUG AND BRASS ACTION NUTS.			
39	1/2" CLASSIC 48 (BRASS) (WALL MOUNTED)	1/2"	1/2"	F	1/2"	1/2" x 1/2" CLASSIC 48 (BRASS) (WALL MOUNTED) COMPLETE WITH O-RING, RECEPTOR PLUG AND BRASS ACTION NUTS.			
40	1/2" CLASSIC 48 (BRASS) (WALL MOUNTED)	1/2"	1/2"	F	1/2"	1/2" x 1/2" CLASSIC 48 (BRASS) (WALL MOUNTED) COMPLETE WITH O-RING, RECEPTOR PLUG AND BRASS ACTION NUTS.			
41	1/2" CLASSIC 48 (BRASS) (WALL MOUNTED)	1/2"	1/2"	F	1/2"	1/2" x 1/2" CLASSIC 48 (BRASS) (WALL MOUNTED) COMPLETE WITH O-RING, RECEPTOR PLUG AND BRASS ACTION NUTS.			
42	1/2" CLASSIC 48 (BRASS) (WALL MOUNTED)	1/2"	1/2"	F	1/2"	1/2" x 1/2" CLASSIC 48 (BRASS) (WALL MOUNTED) COMPLETE WITH O-RING, RECEPTOR PLUG AND BRASS ACTION NUTS.			
43	1/2" CLASSIC 48 (BRASS) (WALL MOUNTED)	1/2"	1/2"	F	1/2"	1/2" x 1/2" CLASSIC 48 (BRASS) (WALL MOUNTED) COMPLETE WITH O-RING, RECEPTOR PLUG AND BRASS ACTION NUTS.			
44	1/2" CLASSIC 48 (BRASS) (WALL MOUNTED)	1/2"	1/2"	F	1/2"	1/2" x 1/2" CLASSIC 48 (BRASS) (WALL MOUNTED) COMPLETE WITH O-RING, RECEPTOR PLUG AND BRASS ACTION NUTS.			
45	1/2" CLASSIC 48 (BRASS) (WALL MOUNTED)	1/2"	1/2"	F	1/2"	1/2" x 1/2" CLASSIC 48 (BRASS) (WALL MOUNTED) COMPLETE WITH O-RING, RECEPTOR PLUG AND BRASS ACTION NUTS.			
46	1/2" CLASSIC 48 (BRASS) (WALL MOUNTED)	1/2"	1/2"	F	1/2"	1/2" x 1/2" CLASSIC 48 (BRASS) (WALL MOUNTED) COMPLETE WITH O-RING, RECEPTOR PLUG AND BRASS ACTION NUTS.			
47	1/2" CLASSIC 48 (BRASS) (WALL MOUNTED)	1/2"	1/2"	F	1/2"	1/2" x 1/2" CLASSIC 48 (BRASS) (WALL MOUNTED) COMPLETE WITH O-RING, RECEPTOR PLUG AND BRASS ACTION NUTS.			
48	1/2" CLASSIC 48 (BRASS) (WALL MOUNTED)	1/2"	1/2"	F	1/2"	1/2" x 1/2" CLASSIC 48 (BRASS) (WALL MOUNTED) COMPLETE WITH O-RING, RECEPTOR PLUG AND BRASS ACTION NUTS.			
49	1/2" CLASSIC 48 (BRASS) (WALL MOUNTED)	1/2"	1/2"	F	1/2"	1/2" x 1/2" CLASSIC 48 (BRASS) (WALL MOUNTED) COMPLETE WITH O-RING, RECEPTOR PLUG AND BRASS ACTION NUTS.			
50	1/2" CLASSIC 48 (BRASS) (WALL MOUNTED)	1/2"	1/2"	F	1/2"	1/2" x 1/2" CLASSIC 48 (BRASS) (WALL MOUNTED) COMPLETE WITH O-RING, RECEPTOR PLUG AND BRASS ACTION NUTS.			

NAVAJO NATION BATHROOM ADDITIONS
 NAVAJO NATION
 CONSTRUCTION DOCUMENTS
 DRAWN BY: NAVJO ENG. & CONSTRUCTION AUTHORITY

DOUGENHOLZ DESIGN STUDIO - ARCHITECTURE, LLC
 8005 Pennsylvania
 Cedar ME
 Auburn, ME 04411
 Tel: 603.228.2505 Fax: 603.228.2500

CONSULTANT INFO & LOGO
 QAE
 1001 Drive Street NE - Albuquerque, NM 87108
 T: 505.243.8900 F: 505.243.8971
 www.qaeboring.com



NO.	DATE	DESCRIPTION
1	6-16-2020	MCP Drawing Set

PROJECT NUMBER: MO-36
 DRAWING FILE:
 DRAWN BY: HCU
 CHECKED BY: HCU
 COPYRIGHT 2020 Navajo Design Studio - Architecture, LLC.

SHEET TITLE
SCHEDULES & DETAILS

SHEET NUMBER
MP501

Appendix B

BUDGET

BUDGET-1:

K2115145

NASCHITTI BATHROOM

ADDITIONS

FY 2023

THE NAVAJO NATION
PROGRAM BUDGET SUMMARY

PART I. Business Unit No.: <u>NEW</u>		Program Title: <u>Naachtii Governance Chapter - Bathroom Addition</u>		Division/Branch: <u>DCD/Executive Branch</u>				
Prepared By: <u>Carlisa Wood, Manager</u>		Phone No.: <u>505-732-5400</u>		Email Address: <u>neschiii@navajochapters.org</u>				
PART II. FUNDING SOURCE(S)	Fiscal Year /Term	Amount	% of Total	PART III. BUDGET SUMMARY	Fund Type Code	(A) NNC Approved Original Budget	(B) Proposed Budget	(C) Difference or Total
NN Fiscal Recovery Funds	10/01/22-09/30/23	\$ 551,748.00	100%	2001 Personnel Expenses				
				3000 Travel Expenses				
				3500 Meeting Expenses				
				4000 Supplies				
				5000 Lease and Rental				
				5500 Communications and Utilities				
				6000 Repairs and Maintenance				
				6500 Contractual Services	6	0	551,748.70 551,748	551,748.70 551,748
				7000 Special Transactions				
				8000 Public Assistance				
				9000 Capital Outlay				
				9500 Matching Funds				
				9500 Indirect Cost				
				TOTAL		\$0.00	\$ 551,748.70	\$ 551,748.70
				PART IV. POSITIONS AND VEHICLES		(D)	(E)	
				Total # of Positions Budgeted:		0	0	
				Total # of Vehicles Budgeted:		0	0	
TOTAL:		\$551,748.00	100%					
PART V. I HEREBY ACKNOWLEDGE THAT THE INFORMATION CONTAINED IN THIS BUDGET PACKAGE IS COMPLETE AND ACCURATE.								
SUBMITTED BY: <u>James Adaski, Deputy Director</u>			APPROVED BY: <u>Calvin Castillo, Executive Director</u>					
Program Manager's Printed Name			Division Director / Branch Chief's Printed Name					
<u>[Signature]</u> Program Manager's Signature and Date			<u>[Signature]</u> Division Director / Branch Chief's Signature and Date			2/8/2022		

THE NAVAJO NATION
PROGRAM PERFORMANCE CRITERIA

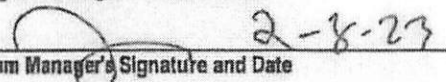
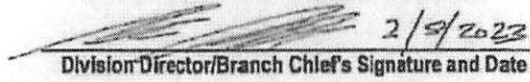
PART I. PROGRAM INFORMATION:									
Business Unit No.: <u>NEW</u>			Program Name/Title: <u>Naschitti Governance Chapter Bathroom Additions</u>						
PART II. PLAN OF OPERATION/RESOLUTION NUMBER/PURPOSE OF PROGRAM:									
PART III. PROGRAM PERFORMANCE CRITERIA:									
		1st QTR		2nd QTR		3rd QTR		4th QTR	
		Goal	Actual	Goal	Actual	Goal	Actual	Goal	Actual
1. Goal Statement:									
To construct 15 bathroom additions for eligible Naschitti Community residents									
Program Performance Measure/Objective:									
To hire contractor to construction 15 bathroom additions for 15 community members						15			
2. Goal Statement:									
Program Performance Measure/Objective:									
3. Goal Statement:									
Program Performance Measure/Objective:									
4. Goal Statement:									
Program Performance Measure/Objective:									
5. Goal Statement:									
Program Performance Measure/Objective:									
PART IV. I HEREBY ACKNOWLEDGE THAT THE ABOVE INFORMATION HAS BEEN THOROUGHLY REVIEWED.									
<u>James Adakai, Deputy Director</u> Program Manager's Printed Name				<u>Calvin Castillo, Executive Director</u> Division Director/Branch Chief's Printed Name					
 Program Manager's Signature and Date <u>2-8-23</u>				 Division Director/Branch Chief's Signature and Date <u>2/9/2023</u>					

THE NAVAJO NATION
DETAILED BUDGET AND JUSTIFICATION

PART I. PROGRAM INFORMATION:			
Program Name/Title: <u>Naschitti Governance Chapter - Bathroom Additions</u>		Business Unit No.: <u>NEW</u>	
PART II. DETAILED BUDGET:			
(A)	(B)	(C)	(D)
Object Code (LOD 6)	Object Code Description and Justification (LOD 7)	Total by DETAILED Object Code (LOD 6)	Total by MAJOR Object Code (LOD 4)
6500	CONTRACTUAL SERVICES Hire contractors to construct bathroom additions for 15 Naschitti community members.		748.70 748.70
6520 AM	Consulting 6530 Consulting - Fees 6540 Consulting - Expenses	275,873.85 275,873.85 AM	\$ 551,748.00
		TOTAL \$ 748.70 748.70	TOTAL \$ 551,748.00

**THE NAVAJO NATION
PROJECT BUDGET SCHEDULE**

PART I. Business Unit No.: <u>NEW</u>													PART II. Project Information																																
Project Title: <u>Naschibi Governance Chapter - Bathroom Additions</u>													Project Type: <u>Bathroom Additions</u>																																
Project Description: <u>Construct 15 bathroom additions for Naschibi Community residence</u>													Planned Start Date: <u>10/1/2022</u>																																
Check one box: <input checked="" type="checkbox"/> Original Budget <input type="checkbox"/> Budget Revision <input type="checkbox"/> Budget Reallocation <input type="checkbox"/> Budget Modification													Planned End Date: <u>9/30/2026</u>																																
PART III. List Project Task separately, such as Plan, Design, Construct, Equip or Furnish.													PART IV. Use Fiscal Year (FY) Quarters to complete the information below. O = Oct.; N = Nov.; D = Dec., etc.				Expected Completion Date if project exceeds 8 FY Qtrs.																												
													FY 2023								FY 2024																								
													1st Qtr.		2nd Qtr.			3rd Qtr.			4th Qtr.				1st Qtr.		2nd Qtr.			3rd Qtr.			4th Qtr.				Date <u>9/30/26</u>								
													O	N	D	J	F	M	A	M	J	Jul	A	S	O	N	D	J	F	M	A	M	J	Jul	A	S	Jul	A	S	Jul	A	S	Jul	A	S
01/01/2023 - 05/01/2023 Advertise for Request for Proposals													x	x	x	x	x	x	x	x	x																								
05/01/2023 - 7/01/23 Initiate contract for services and notice to proceed																			x	x	x																								
7/1/2023 Begin Construction																					x	x	x	x	x	x	x	x	x	x	x	x	x	x	x	x	x	x	x	x	x	x	x	x	x
7/1/2026 Complete Final Close-out of project																																													
PART V.													\$		\$			\$			\$				\$		\$			\$			\$				PROJECT TOTAL								
Expected Quarterly Expenditures																		551,748.00															551,748.00												

FOR OMB USE ONLY: Resolution No: _____ FMIS Set Up Date: _____ Company No: _____ OMB Analyst: _____

BUDGET-2:

K2115146

NASCHITTI RURAL

ADDRESSING

FY 2023

THE NAVAJO NATION
PROGRAM BUDGET SUMMARY

Page 1 of 3
BUDGET FORM 1



PART I. Business Unit No.: NEW Program Title: Naschitti Governance Chapter - Rural Addressing Division/Branch: DCD/Executive
 Prepared By: Carissa Wood, Manager Phone No.: 505-732-6400 Email Address: naschitti@navajochapters.org

PART II. FUNDING SOURCE(S)	Fiscal Year /Term	Amount	% of Total	PART III. BUDGET SUMMARY				
				Fund Type Code	(A) NNC Approved Original Budget	(B) Proposed Budget	(C) Difference or Total	
WIN Fiscal Recovery Funds	10/1/22-9/30/28	\$70,000	100%					
				2001 Personnel Expenses				
				3000 Travel Expenses				
				3500 Meeting Expenses				
				4000 Supplies	6	0	50,800 00	50,800 00
				5000 Lease and Rental				
				6500 Communications and Utilities				
				8000 Repairs and Maintenance	6 000	0 000	29,489 00	29,489 00
				6500 Contractual Services	6	0	19,200 00	19,200 00
				7000 Special Transactions				
				8000 Public Assistance				
				8000 Capital Outlay				
				9500 Matching Funds				
				9500 Indirect Cost				
				TOTAL		\$0.00	\$ 70,000.00	\$ 70,000.00
TOTAL: \$70,000.00 100%				PART IV. POSITIONS AND VEHICLES		(D)	(E)	
				Total # of Positions Budgeted:		0	2	
				Total # of Vehicles Budgeted:		0	0	

PART V. I HEREBY ACKNOWLEDGE THAT THE INFORMATION CONTAINED IN THIS BUDGET PACKAGE IS COMPLETE AND ACCURATE.

SUBMITTED BY: James Adakal, Deputy Director APPROVED BY: Colin Castillo, Executive Director
 Program Manager's Printed Name Division Director / Branch Chief's Printed Name
2-8-23 2/8/2023
 Program Manager's Signature and Date Division Director / Branch Chief's Signature and Date

THE NAVAJO NATION
PROGRAM PERFORMANCE CRITERIA

PART I. PROGRAM INFORMATION:									
Business Unit No.: <u>NEW</u>			Program Name/Title: <u>Naschitti Governance Chapter Rural Addressing</u>						
PART II. PLAN OF OPERATION/RESOLUTION NUMBER/PURPOSE OF PROGRAM:									
PART III. PROGRAM PERFORMANCE CRITERIA:									
		1st QTR		2nd QTR		3rd QTR		4th QTR	
		Goal	Actual	Goal	Actual	Goal	Actual	Goal	Actual
1. Goal Statement:									
To purchase materials and Hire 2 individuals to install signage for rural addressing system									
Program Performance Measure/Objective:									
To purchase and install rural addressing signage for Naschitti Community						2			
2. Goal Statement:									
Program Performance Measure/Objective:									
3. Goal Statement:									
Program Performance Measure/Objective:									
4. Goal Statement:									
Program Performance Measure/Objective:									
5. Goal Statement:									
Program Performance Measure/Objective:									
PART IV. I HEREBY ACKNOWLEDGE THAT THE ABOVE INFORMATION HAS BEEN THOROUGHLY REVIEWED.									
<u>James Adakai, Deputy Director</u> Program Manager's Printed Name				<u>Calvin Castillo, Executive Director</u> Division Director/Branch Chief's Printed Name					
 Program Manager's Signature and Date				 Division Director/Branch Chief's Signature and Date					

FY 2023
AK

THE NAVAJO NATION
 DETAILED BUDGET AND JUSTIFICATION

Page 3 of 3
 BUDGET FORM 4 *AK*

PART I. PROGRAM INFORMATION:			
Program Name/Title: <u>Nashon:hi Governance Chapter - Rural Addressing</u> <i>AK</i>		Business Unit No.: <u>NAW</u> <i>AK</i>	
PART II. DETAILED BUDGET:			
(A)	(B)	(C)	(D)
Object Code (LOD 8)	Object Code Description and Justification (LOD 7)	Total by DETAILED Object Code (LOD 6)	Total by MAJOR Object Code (LOD 4)
4000 <i>AK</i>	Supplies		50,800 <i>AK</i>
4410 <i>AK</i>	Operating Supplies	49,600 <i>AK</i>	
	4420 General Operating Supplies		
4700 <i>AK</i>	Fuel	1,200 <i>AK</i>	
	4710 Gasoline		
6500 <i>AK</i>	Contractual Services <i>AK</i>		
6520 <i>AK</i>	Consulting <i>AK</i>	9,600 <i>AK</i>	19,200 <i>AK</i>
	6520 Consulting - Fees <i>AK</i>	9,600 <i>AK</i>	
	6540 Consulting - Expenses <i>AK</i>		
TOTAL		70,000 <i>AK</i>	70,000 <i>AK</i>

**THE NAVAJO NATION
PROJECT BUDGET SCHEDULE**

PART I. Business Unit No.: <u>NEW</u>										PART II. Project Information																							
Project Title: <u>Naschidi Governance Chapter - Rural Addressing</u>										Project Type: <u>Rural Addressing</u>																							
Project Description: <u>Purchase materials and hire 2 individuals to install rural addressing signage for the Naschidi Community</u>										Planned Start Date: <u>10/1/2022</u>																							
Check one box: <input checked="" type="checkbox"/> Original Budget <input type="checkbox"/> Budget Revision <input type="checkbox"/> Budget Reallocation <input type="checkbox"/> Budget Modification										Planned End Date: <u>9/30/2025</u>																							
										Project Manager: <u>Carissa Wood</u>																							
PART III. List Project Task separately, such as Plan, Design, Construct, Equip or Furnish.	PART IV. Use Fiscal Year (FY) Characters to complete the information below. O = Oct; N = Nov; D = Dec., etc.																Expected Completion Date if project exceeds 6 FY Ctrs.																
	FY 2023								FY 2024								Date																
	1st Qtr.		2nd Qtr.			3rd Qtr.			4th Qtr.		1st Qtr.		2nd Qtr.			3rd Qtr.			4th Qtr.														
	O	N	D	J	F	M	A	M	J	J	A	S	O	N	D	J	F	M	A	M	J	J	A	S	J								
<u>01/01/2023 - 07/31/2023</u> Complete Data Entry into the Rural Addressing Website and Verify Information with NAAA				X	X	X	X	X	X																								
<u>07/01/23 - 09/01/2024</u> Purchase Signage Materials and Supplies for all Streets and Homes										X	X	X	X	X	X	X	X	X	X	X	X	X	X	X									
<u>7/1/2023</u> Complete Final Close-Out of Projects																																	
PART V.	\$		\$			\$			\$		\$		\$			\$			\$		\$		\$		\$		\$		PROJECT TOTAL				
Expected Quarterly Expenditures			19,200.00			50,000.00																							570,000.00				



FOR ORB USE ONLY: Resolution No: _____ FMIS Set Up Date: _____ Company No: _____ OMB Analyst: _____

BUDGET-3:
K2115153
NASCHITTI HOUSE
WIRING

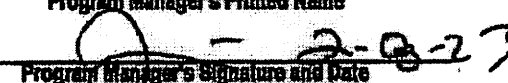

FY 2023

THE NAVAJO NATION
PROGRAM BUDGET SUMMARY

Page 1 of 3
BUDGET FORM 1

PART I. Business Unit No.: <u>NEW</u>		Program Title: <u>Nasch'itli Governance Chapter - House Wiring</u>		Division/Branch: <u>DCD/Executive</u>				
Prepared By: <u>Carlisa Wood, Manager</u>		Phone No.: <u>605-732-5400</u>		Email Address: <u>naschitli@navajochapters.org</u>				
PART II. FUNDING SOURCE(S)	Fiscal Year /Term	Amount	% of Total	PART III. BUDGET SUMMARY	Fund Type Code	(A) NNC Approved Original Budget	(B) Proposed Budget	(C) Difference or Total
NA Fiscal Recovery Funds	10/1/22-9/30/25	\$ 525,000.00	100%	2001 Personnel Expenses				
				3000 Travel Expenses				
				3500 Meeting Expenses				
				4000 Supplies	6 Att	0 Att	225,000 Att	225,000 Att
				5000 Lease and Rental				
				5500 Communications and Utilities				
				6000 Repairs and Maintenance				
				6500 Contractual Services	6	0	300,000	300,000
				7000 Special Transactions				
				8000 Public Assistance	6 Att	0 Att	225,000 Att	225,000 Att
				9000 Capital Outlay				
				9500 Matching Funds				
				9500 Indirect Cost				
				TOTAL		\$0.00	\$ 525,000.00	\$ 525,000.00
				PART IV. POSITIONS AND VEHICLES		(D)	(E)	
				Total # of Positions Budgeted:		0	0	
				Total # of Vehicles Budgeted:		0	0	
TOTAL:		\$525,000.00	100%					
PART V. I HEREBY ACKNOWLEDGE THAT THE INFORMATION CONTAINED IN THIS BUDGET PACKAGE IS COMPLETE AND ACCURATE.								
SUBMITTED BY: <u>James Adakai, Deputy Director</u>			APPROVED BY: <u>Calvin Castillo, Executive Director</u>					
Program Manager's Printed Name			Division Director / Branch Chief's Printed Name					
								
Program Manager's Signature and Date			Division Director / Branch Chief's Signature and Date					

**THE NAVAJO NATION
PROGRAM PERFORMANCE CRITERIA**

PART I. PROGRAM INFORMATION:												
Business Unit No.: <u>NEW</u>			Program Name/Title: <u>Naschitli Governance Chapter House Wiring</u>									
PART II. PLAN OF OPERATION/RESOLUTION NUMBER/PURPOSE OF PROGRAM:												
PART III. PROGRAM PERFORMANCE CRITERIA:												
					1st QTR		2nd QTR		3rd QTR		4th QTR	
					Goal	Actual	Goal	Actual	Goal	Actual	Goal	Actual
1. Goal Statement:												
<u>To purchase supplies and hire electrical contractors to upgrade house wiring for residents.</u>												
Program Performance Measure/Objective:												
<u>To complete House Wiring Project for Naschitli Community</u>									1			
2. Goal Statement:												
Program Performance Measure/Objective:												
3. Goal Statement:												
Program Performance Measure/Objective:												
4. Goal Statement:												
Program Performance Measure/Objective:												
5. Goal Statement:												
Program Performance Measure/Objective:												
PART IV. I HEREBY ACKNOWLEDGE THAT THE ABOVE INFORMATION HAS BEEN THOROUGHLY REVIEWED.												
<u>James Adakai, Deputy Director</u> Program Manager's Printed Name					<u>Calvin Castillo, Executive Director</u> Division Director/Branch Chief's Printed Name							
 Program Manager's Signature and Date									2/8/2023 Division Director/Branch Chief's Signature and Date			

THE NAVAJO NATION
DETAILED BUDGET AND JUSTIFICATION

PART I. PROGRAM INFORMATION:			
Program Name/Title: <u>Naschitti Governance Chapter - House Wiring</u>		Business Unit No.: <u>NEW</u>	
PART II. DETAILED BUDGET:			
(A)	(B)	(C)	(D)
Object Code (LOD 6)	Object Code Description and Justification (LOD 7)	Total by DETAILED Object Code (LOD 6)	Total by MAJOR Object Code (LOD 4)
8300 8500 8500 8500	Public Assistance Infrastructure (non cap) 8530 House Wiring Electrical Wiring Materials & Supplies Purchase materials and electrical supplies to install new/upgrade electrical wiring in community members homes.	\$ 225,000.00	225,000 \$
6500	CONTRACTUAL SERVICES Hire electrical contractors to install/upgrade electrical wiring in homes for Naschitti community members.	\$ 300,000.00	300,000 \$
6520 6530 6540	Consulting 6530 consulting - Fees 6540 Consulting - Expenses	150,000 150,000	
TOTAL		\$ 525,000.00	\$ 525,000.00

**THE NAVAJO NATION
PROJECT BUDGET SCHEDULE**

PART I. Business Unit No.: <u>NEW</u> Project Title: <u>Naschidi Chapter - House Wiring</u> Project Description: <u>Purchase materials and electrical supplies to install new/upgrade electrical wiring and hire electrical contractors to install/upgrade wiring in homes for Naschidi Community Members</u> Check one box: <input checked="" type="checkbox"/> Original Budget <input type="checkbox"/> Budget Revision <input type="checkbox"/> Budget Reallocation <input type="checkbox"/> Budget Modification										PART II. Project Information Project Type: <u>House Wiring</u> Planned Start Date: <u>10/1/2022</u> Planned End Date: <u>8/30/2026</u> Project Manager: <u>Crissa Wood</u>																							
PART III. List Project Task separately, such as Plan, Design, Construct, Equip or Furnish.	PART IV. Use Fiscal Year (FY) Quarters to complete the information below. O = Oct.; N = Nov.; D = Dec., etc.																Expected Completion Date if project exceeds 8 FY Qtrs. Date: <u>9/30/2026</u>																
	FY 2023								FY 2024																								
	1st Qtr.		2nd Qtr.			3rd Qtr.			4th Qtr.		1st Qtr.		2nd Qtr.			3rd Qtr.		4th Qtr.		Date													
	O	N	D	J	F	M	A	M	J	J	A	S	O	N	D	J	F	M	A	M	J	J	A	S	O	N	D	J	F	M			
01/01/2023 - 05/01/2023 Advertise for Request for Proposals			x	x	x	x																											
05/01/2023 - 07/01/2023 Solicit contract for services and procure							x	x	x																								
07/01/2023 - 07/01/2024 Begin Construction									x	x	x	x	x	x	x	x	x	x	x	x	x												
07/01/2024 Begin Close-out of project																								x									
PART V.	\$		\$			\$			\$		\$			\$		\$		\$		\$		PROJECT TOTAL											
Expected Quarterly Expenditures			225,000.00			300,000.00														\$525,000.00													

FOR OMB USE ONLY: Resolution No: _____ FMIS Set Up Date: _____ Company No: _____ OMB Analyst: _____

Appendix C
DISBURSEMENT
SCHEDULE



DR. BUU NYGREN *PRESIDENT*
RICHELLE MONTOYA *VICE PRESIDENT*

The Navajo Nation | Yideeskáądi Nitsáhákees

SUBRECIPIENT AGREEMENT

Between

THE NAVAJO NATION

And

Naschitti Community Governance

Appendix C

Disbursement Schedule

The Navajo Nation Fiscal Recovery Fund Office will make an initial disbursement of **25% (\$286,687.18)** of the total allocated amount of **\$1,146,748.70** to the **SUBRECIPIENT**. **75% (\$215,015.38)** of this funding must be expended before any additional amounts will be disbursed.

- | | | |
|-----------------------------------|---------------|-------------|
| 1) Bathroom Addition (K2115145) = | \$551, 748.70 | TOTAL FUNDS |
| 2) Rural Addressing (K2115146) = | \$70,000.00 | |
| 3) House Wiring (K2115153) = | \$525,000.00 | |

2. Second Disbursement 25%, after 75% of the initial has been spent:

- **\$286,687.18**

3. Third Disbursement 25%, after 75% of the initial has been spent:

- **\$286,687.18**

4. Final Disbursement 25%, after 75% of the second disbursement has been spent:

- **\$286,687.18**

*The **SUBRECIPIENT** must provide documentation that it has obligated or expended 75% of its prior disbursement installment before OOC will release the next disbursement installment. If the **SUBRECIPIENT** expends 75% of its disbursement installment prior to the end of a twelve-month period, the **SUBRECIPIENT** may request to the FRF Office, the Administrative Oversight, and OOC that OOC release the next disbursement installment prior to the end of that twelve-month period

CONCURRED BY:

Calvin Castillo, Executive Director
 Division of Community Development

Appendix D
EXPENDITURE PLAN

Expenditure Plan-1:
NASCHITTI BATHROOM
ADDITION



**NAVAJO NATION DEPARTMENT OF JUSTICE
OFFICE OF THE ATTORNEY GENERAL**

ETHEL B. BRANCH
Attorney General

HEATHER CLAH
Deputy Attorney General

**DEPARTMENT OF JUSTICE
INITIAL ELIGIBILITY DETERMINATION
FOR NAVAJO NATION FISCAL RECOVERY FUNDS**

RFS/HK Review #: HK 0416

Date & Time Received: 3/28/23 at 16:59

Date & Time of Response: 4/10/23 at 918 am

Entity Requesting FRF: Naschitti Community Governance (Naschitti Chapter)

Title of Project: Bathroom Additions

Administrative Oversight: DCD

Amount of Funding Requested: \$551,748.70

Eligibility Determination:

- FRF eligible
 FRF ineligible
 Additional information requested

FRF Eligibility Category:

- (1) Public Health and Economic Impact
 (2) Premium Pay
 (3) Government Services/Lost Revenue
 (4) Water, Sewer, Broadband Infrastructure

U.S. Department of Treasury Reporting Expenditure Category: _____

1.14 Other Public Health Services

Returned for the following reasons (Ineligibility Reasons/Paragraphs 5.E.(1)-(10) of FRF Procedures):

- Missing Form
- Supporting documentation missing
- Project will not be completed by 12/31/2026
- Ineligible purpose
- Submitter failed to timely submit CARES reports
- Additional information submitted is insufficient to make a proper determination

- Expenditure Plan incomplete
- Funds will not be obligated by 12/31/2024
- Incorrect Signatory
- Inconsistent with applicable NN or federal laws

Other Comments: _____

Name of DOJ Reviewer: Rudy Anaya, Tax and Finance Unit

Signature of DOJ Reviewer: 

Disclaimers:
If additional information has been requested and you wish to provide it, please resubmit all the required forms updated to include the additional information. Full resubmission will expedite the Initial Eligibility Determination process. Therefore, please include a new RFS form indicating resubmission, revised Appendix A, Budget Form 1, and other supporting documents. Please email your resubmission to arpa@nndoj.org. Please be aware that under Resolution DFS-31-21 a Project or Program can only be reviewed twice, therefore it is critical that you include all the requested additional information for your second submission.

An NNDÓJ Initial Eligibility Determination is based on the documents provided, which NNDÓJ will assume are true, correct, and complete. Should the Project or Program change in any material way after the initial determination, the requestor must seek the advice of NNDÓJ. An initial determination is limited to review of the Project or Program as it relates to whether the Project or Program is a legally allowable use – it does not serve as an opinion as to whether or not the Project or Program should be funded, nor does it serve as an opinion as to whether or not the amount requested is reasonable or accurate.

**THE NAVAJO NATION
FISCAL RECOVERY FUNDS REQUEST FORM & EXPENDITURE PLAN
FOR GOVERNANCE-CERTIFIED CHAPTERS**

Part 1. Identification of parties.

Governance-Certified Chapter requesting FRF: Naschitti Community Governance (Naschitti Chapter) Date prepared: 11/17/22
Chapter's mailing address: Drawer D, Sheepsprings, NM 87364 phone & email: 505-732-5400
Sheepsprings, NM 87364 website (if any): naschitti@navajochapters.org
This Form prepared by: Carissa Wood phone/email: 505-732-5400
Chapter Manager cwood@nnchapters.org
CONTACT PERSON'S name and title CONTACT PERSON'S title

Title and type of Project: Bathroom Additions

Chapter President: Rhonda Herbert phone & email: 505-870-4991 rherbert@naataanii.org
Chapter Vice-President: Kee Y. Gee phone & email: 480-599-8755 kygee@naataanii.org
Chapter Secretary: Orlinda Skyberg phone & email: 214-693-8804 orlin.r.skyberg@gmail.com
Chapter Treasurer: Orlinda Skyberg phone & email: 214-693-8804 orlin.r.skyberg@gmail.com
Chapter Manager or CSC: Carissa Wood phone & email: 505-732-5400 cwood@nnchapters.org
DCD/Chapter ASC: Patricia Begay phone & email: 928-871-7515 pdbegay@nndcd.org

List types of Subcontractors or Subrecipients that will be paid with FRF (if known):
551,747.70 document attached
Amount of FRF requested: \$551,748.00 FRF funding period: 10/1/2022 - 9/30/2026
Indicate Project starting and ending/working date

Part 2. Expenditure Plan details.

(a) Describe the Program(s) and/or Project(s) to be funded, including how the funds will be used, for what purposes, the location(s) to be served, and what COVID-related needs will be addressed:

This project will consist of allocating funds in the amount of 551,747.70 for Contractual Services to hire a contractor to build 15 bathroom additions for Naschitti community members. These bathroom additions will meet the needs of community members to allow for water and wastewater connections with the assistance of OEH, IHS and NTUA according to current building codes.

document attached

(b) Explain how the Program or Project will benefit the Navajo Nation, Navajo communities, or the Navajo People:

This project will benefit the Naschitti Community members by providing adequate indoor plumbing and water access for household use which will provide safe and healthy living standards for families who have limited income and resources during this pandemic.

document attached

(c) A prospective timeline showing the estimated date of completion of the Project and/or each phase of the Project. Disclose any challenges that may prevent you from incurring costs for all funding by December 31, 2024 and/or fully expending funds and completing the Program(s) or Project(s) by December 31, 2026:

APPENDIX A

**Current: Assess and identify homes/residents who are in need of bathroom additions; January 2023
Advertise for Request for Proposals; May 2023 Initiate contract for services and notice to proceed;
July 2023 Begin construction; July 2026 complete final close out of project.**

document attached

(d) Identify who will be responsible for implementing the Program or Project:

The Naschitti Community Governance will monitor and keep project on task with Division of Community Development providing oversight.

document attached

(e) Explain who will be responsible for operations and maintenance costs for the Project once completed, and how such costs will be funded prospectively:

The home owners will be responsible for utility costs and maintenance of thier services after hook up.

document attached

(f) State which of the 66 Fiscal Recovery Fund expenditure categories in the attached U.S. Department of the Treasury Appendix 1 listing the proposed Program or Project falls under, and explain the reason why:

1.14 Other Public Health Services^A

Naschitti Community Governance (Naschitti Chapter) is respectfully requesting funding to provide bathroom addition assistance to local community members with limited income/resources to provide better living enviroment to increase their health and safety.

document attached

Part 3. Additional documents.

List here all additional supporting documents attached to this FRF Expenditure Plan (or indicate N/A).

**Exhibit B: Budget and Expenditure Plan
Naschitti Community Governance supporting resolution**

Chapter Resolution attached

Part 4. Affirmation by Funding Recipient.

Funding Recipient affirms that its receipt of Fiscal Recovery Funds and the implementation of this FRF Expenditure Plan shall be in accordance with Resolution No. CJV-41-21, the ARPA, ARPA Regulations, and with all applicable federal and Navajo Nation laws, regulations, and policies.

Chapters Preparer: *CAISSIN NICOZI*
Signature of Preparer CONTACT PERSON
Approved by: *CAISSIN NICOZI*
Signature of Chapter Manager or CEO

Approved by: *[Signature]*
Signature of Chapter Approval or your President

Approved by: *Patricia Begay*
Signature of Fiscal Group CEO

Approved to submit for Review: *Sean Johnson UNERFO*
Signature of DCO Director

FY 2023

THE NAVAJO NATION
PROGRAM BUDGET SUMMARY

Page 1 of 3
BUDGET FORM 1

PART I. Business Unit No.: NEW **Program Title:** Naschitti Governance Chapter - Bathroom Addition **Division/Branch:** DCD/Executive Branch

Prepared By: Carissa Wood, Manager **Phone No.:** 505-732-5400 **Email Address:** naschitti@navajochapters.org



PART II. FUNDING SOURCE(S)	Fiscal Year / Term	Amount	% of Total	PART III. BUDGET SUMMARY				
				Fund Type Code	(A) NNC Approved Original Budget	(B) Proposed Budget	(C) Difference or Total	
NN Fiscal Recovery Funds	10/01/22-09/30/25	\$ 651,748.00	100%					
				2001 Personnel Expenses				
				3000 Travel Expenses				
				3500 Meeting Expenses				
				4000 Supplies				
				5000 Lease and Rental				
				5500 Communications and Utilities				
				6000 Repairs and Maintenance				
				6500 Contractual Services	8	0	551,748.70	551,748.70
				7000 Special Transactions			-551,748	-551,748
				8000 Public Assistance				
				9000 Capital Outlay				
				9500 Matching Funds				
				9500 Indirect Cost				
				TOTAL		\$0.00	\$ 551,747.70	\$ -551,748.00
				PART IV. POSITIONS AND VEHICLES		(D)	(E)	
				Total # of Positions Budgeted:		0	0	
				Total # of Vehicles Budgeted:		0	0	
TOTAL:				\$551,748.00	100%			

PART V. I HEREBY ACKNOWLEDGE THAT THE INFORMATION CONTAINED IN THIS BUDGET PACKAGE IS COMPLETE AND ACCURATE.

SUBMITTED BY: James Adakai, Deputy Director **APPROVED BY:** Cavin Castillo, Executive Director
Program Manager's Printed Name Division Director / Branch Chief's Printed Name

[Signature] 2-8-23 [Signature] 2/8/2022
Program Manager's Signature and Date Division Director / Branch Chief's Signature and Date

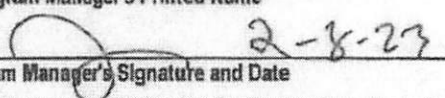
THE NAVAJO NATION
PROGRAM PERFORMANCE CRITERIA

PART I. PROGRAM INFORMATION:									
Business Unit No.: <u>NEW</u>			Program Name/Title: <u>Naschitti Governance Chapter Bathroom Additions</u>						
PART II. PLAN OF OPERATION/RESOLUTION NUMBER/PURPOSE OF PROGRAM:									
PART III. PROGRAM PERFORMANCE CRITERIA:									
		1st QTR		2nd QTR		3rd QTR		4th QTR	
		Goal	Actual	Goal	Actual	Goal	Actual	Goal	Actual
1. Goal Statement:									
To construct 15 bathroom additions for eligible Naschitti Community residents									
Program Performance Measure/Objective:									
To hire contractor to construction 15 bathroom additions for 15 community members						15			
2. Goal Statement:									
Program Performance Measure/Objective:									
3. Goal Statement:									
Program Performance Measure/Objective:									
4. Goal Statement:									
Program Performance Measure/Objective:									
5. Goal Statement:									
Program Performance Measure/Objective:									
PART IV. I HEREBY ACKNOWLEDGE THAT THE ABOVE INFORMATION HAS BEEN THOROUGHLY REVIEWED.									
James Adakai, Deputy Director				Calvin Castillo, Executive Director					
_____ Program Manager's Printed Name				_____ Division Director/Branch Chief's Printed Name					
 Program Manager's Signature and Date <u>2-8-23</u>				 Division Director/Branch Chief's Signature and Date <u>2/9/2023</u>					

FY 2023

**THE NAVAJO NATION
DETAILED BUDGET AND JUSTIFICATION**

Page 3 of 3
BUDGET FORM 4

PART I. PROGRAM INFORMATION:			
Program Name/Title: <u>Naschtii Governance Chapter - Bathroom Additions</u>		Business Unit No.: <u>NEW</u>	
PART II. DETAILED BUDGET:			
(A)	(B)	(C)	(D)
Object Code (LOD 6)	Object Code Description and Justification (LOD 7)	Total by DETAILED Object Code (LOD 6)	Total by MAJOR Object Code (LOD 4)
6500	CONTRACTUAL SERVICES Hire contractors to construct bathroom additions for 15 Naschtii community members.		7427.00 \$ 551,748.00
6520 AN	Consulting ^{per} 6530 Consulting - Fees ^{per} 6540 Consulting - Expenses ^{per}	275,873.85 ^{per} 275,873.85 ^{per}	
TOTAL		\$ 551,748.00	\$ 551,748.00

**THE NAVAJO NATION
PROJECT BUDGET SCHEDULE**

PART I. Business Unit No.: <u>NEW</u>										PART II. Project Information																									
Project Title: <u>Naschii Governance Chapter - Bathroom Additions</u>										Project Type: <u>Bathroom Additions</u>																									
Project Description: <u>Construct 15 bathroom additions for Naschii Community residence</u>										Planned Start Date: <u>10/1/2022</u>																									
Check one box: <input checked="" type="checkbox"/> Original Budget <input type="checkbox"/> Budget Revision <input type="checkbox"/> Budget Reallocation <input type="checkbox"/> Budget Modification										Planned End Date: <u>9/30/2028</u>																									
										Project Manager: <u>Cassie Wood</u>																									
PART III.	PART IV. Use Fiscal Year (FY) Quarters to complete the information below. O = Oct.; N = Nov.; D = Dec., etc.																		Expected Completion Date if project exceeds 8 FY Qtrs.																
List Project Task separately, such as Plan, Design, Construct, Equip or Furnish.	FY 2023									FY 2024									Date <u>9/30/26</u>																
	1st Qtr.			2nd Qtr.			3rd Qtr.			4th Qtr.			1st Qtr.			2nd Qtr.			3rd Qtr.			4th Qtr.													
	O	N	D	J	F	M	A	M	J	Jul	A	S	O	N	D	J	F	M	A	M	J	Jul	A	S	Jul	A	S								
01/01/2023 - 05/01/2023 Advertise for Request for Proposals				x	x	x	x	x																											
05/01/2023 - 7/01/23 Initiate contract for services and notice to proceed							x	x	x																										
7/1/2023 Begin Construction										x	x	x	x	x	x	x	x	x	x	x	x	x	x	x											
7/1/2026 Complete Final Close-out of project																												x							
PART V.	\$			\$			\$			\$			\$			\$			\$			PROJECT TOTAL													
Expected Quarterly Expenditures							651,748.00															651,748.00 21,748.00 651,748.00													

FOR OMB USE ONLY: Resolution No: _____ FMS Set Up Date: _____ Company No: _____ OMB Analyst: _____

Navajo Engineering And Construction Authority

P.O. Box 969
No. 1 Uranium Blvd.
Shiprock, NM 86720

Phone: (505) 210-7070
Fax: (505) 210-7069

To: Address:	Division Of Community Development Window Rock, AZ	Contact: Phone: Fax:
Project Name: Project Location:	Bathroom Additions - Centralized Construction - 2 Units Or More	Bid Number: Bid Date: 2/3/2021

As requested, NECA is providing a more detailed breakdown to construct two (2) bathroom units. Let us know if you need anything else.

Item #	Item Description	Estimated Quantity	Unit	Unit Price	Total Price
5	Mobilization	1.00	LS	62,675.84	62,675.84
10	Foundation	2.00	EACH	29,522.49	59,044.98
15	Framing/Scaffolding	2.00	EACH	57,620.10	115,240.20
20	Rough/Trim Electrical	2.00	EACH	29,800.75	59,601.50
25	Rough/Trim Plumbing	2.00	EACH	26,889.38	53,778.76
30	Exterior Finish	2.00	EACH	25,254.52	50,509.04
35	Interior Finish	2.00	EACH	25,892.15	51,784.30
				Bid Price Subtotal:	469,402.22
				Total Navajo Nation Sales Tax @ 0.09%:	42,164.13
				Total Bid Price:	511,566.35

Notes

• Pricing is for Budgetary Purposes Only - When individual items and quantities of units are established, NECA will bid each item accordingly.

\$36,783.18 per unit

ACCEPTED:

The above prices, specifications and conditions are satisfactory and are hereby accepted.

Buyer: _____

Signature: _____

Date of Acceptance: _____

CONFIRMED:

Navajo Engineering And Construction Authority

Authorized Signature: _____

Estimator: Andrew Riddell

ariddell@navajoad

Naschitti Community Governance

PO Drawer D Sheep Springs, New Mexico 87161
Phone: 505 733 5402 Fax: 505 733 5406



NAS-23-12-004

RESOLUTION OF NASCHITTI COMMUNITY GOVERNANCE

NASCHITTI COMMUNITY GOVERNANCE APPROVES AND ACCEPTS THE AMERICAN RESCUE PLAN ACT (ARPA) – NAVAJO NATION FISCAL RECOVERY FUND EXPENDITURE PLANS FOR THE SELECTION OF THE BATHROOM ADDITIONS PROJECT IN THE AMOUNT OF \$551,747.70 FOR THE NEEDS OF THE NASCHITTI COMMUNITY

WHEREAS:

1. Pursuant to N.N.C. Title 26, Chapter 1, Section 3(A), Section 1(B)(1) and Section 1(B)(2) under the Local Government Act, Naschitti Community Governance is a certified local governmental entity of the Navajo Nation and is vested with the authority to address local concerns and the authority to make decisions with responsibility and accountability; and
2. To support the efforts of the Navajo Nation to mitigate the effects of the COVID-19 Pandemic, the ARPA Fiscal Recovery Funds were allocated to develop the basic infrastructure to improve lives of people who have lived without water, electricity and "basic services to support their daily activities, health, and welfare"; and
3. The Navajo Nation Council approved CJN-29-22, in response to the COVID-19 Pandemic in the best interest of the people; "An Action Relating to the Naabiki'iyati' Committee and Navajo Nation Council; Allocating \$1,070,298,867 of Navajo Nation Fiscal Recovery Funds; Approving the Navajo Nation Fiscal Recovery Fund Expenditure Plans for: Chapter Assistance; Public Safety Emergency Communications; E911; Rural Addressing Projects; Cyber Security; Public Health Projects; Economic Development Projects; Hardship Assistance; Water and Wastewater Projects; Broadband Projects; Home Electricity Connection and Electricity Capacity Projects; Housing Projects and Manufactured Housing Facilities; Bathroom Addition Projects; Construction Contingency Funding; and Reduced Administrative Funding; and
4. The Naschitti Community Governance accepts the allocations for the ARPA-NNFRF allocation in the amount of \$551,747.70 for the Naschitti Community; and
5. The Naschitti Community Governance Administration will be the point of contact on all administrative matters.
6. Naschitti Community Governance (Chapter) affirms that the Chapter will only use awarded Fiscal Recovery Funds and implement this FRF Expenditure Plan in compliance with the ARPA, ARPA Regulations, and with all applicable federal and Navajo Nation laws, regulations, and policies.

Enshela Herbert
Commission President

Ray L. Lee
Commission Vice President

Christy Shroyer
Commission Secretary/Treasurer

Heath Bryant
Commission Member

Michael L. Lee
Commission Member

Naschitti Community Governance

PO Box 13, Sheepcamp, New Mexico 87564
Phone: 505.732.5401-5402 Fax: 505.732.5406



NAS-23-12-004 – Cont'd

NOW, THEREFORE, BE IT RESOLVED THAT:

The Naschitti Community Governance hereby approves and accepts the ARPA – Navajo Nation Fiscal Recovery Fund Expenditure Plans for the selection the Bathroom Additions In the amount of \$551,747.70 for the needs of the Naschitti Community.

CERTIFICATION

I, hereby certify that the foregoing Resolution was duly considered by Naschitti Community Governance Commission and moved for adoption by Hoskie Bryant and seconded by Kee Y Gee at a duly called meeting at Naschitti, (New Mexico) at which a quorum was present and that same was passed by a vote of -4- yeas and -0- nays on this 4th day of December 2022.

A handwritten signature in black ink, appearing to read "Rhonda Herbert", written over a horizontal line.

Rhonda Herbert, Commission President
Naschitti Community Governance

AMENDED CERTIFICATION

I, hereby certify that the foregoing Resolution was duly considered by Naschitti Community Governance Commission and moved for adoption by Orlin Skyberg and seconded by Tammy Yazzie at a duly called meeting at Naschitti, (New Mexico) at which a quorum was present and that same was passed by a vote of -3- yeas and -0- nays on this 19th day of February, 2023.

A handwritten signature in black ink, appearing to read "Rhonda Herbert", written over a horizontal line.

Rhonda Herbert, Commission President
Naschitti Community Governance

Rhonda Herbert
Commission President

Kee Y Gee
Commission Vice President

Orlin Skyberg
Commission Secretary/Treasurer

Hoskie Bryant
Commission Member

Michael Lee
Commission Member

Expenditure Plan-2:
NASCHITTI RURAL
ADDRESSING



**NAVAJO NATION DEPARTMENT OF JUSTICE
OFFICE OF THE ATTORNEY GENERAL**

ETHEL B. BRANCH
Attorney General

HEATHER CLAH
Deputy Attorney General

**DEPARTMENT OF JUSTICE
INITIAL ELIGIBILITY DETERMINATION
FOR NAVAJO NATION FISCAL RECOVERY FUNDS**

RFS/HK Review #: HK 0417

Date & Time Received: 3/28/23 at 16:58

Date & Time of Response: 4/7/23 at 8:59am

Entity Requesting FRF: Naschitl Community Governance (Naschitl Chapter)

Title of Project: Rural Addressing

Administrative Oversight: Division of Community Development

Amount of Funding Requested: \$70,000.00

Eligibility Determination:

- FRF eligible
 FRF ineligible
 Additional information requested

FRF Eligibility Category:

- (1) Public Health and Economic Impact
 (2) Premium Pay
 (3) Government Services/Lost Revenue
 (4) Water, Sewer, Broadband Infrastructure

U.S. Department of Treasury Reporting Expenditure Category: _____

1.14 Other Public Health Services

Returned for the following reasons (Ineligibility Reasons/Paragraphs 5.E.(1)-(10) of FRF Procedures):

- | | |
|--|--|
| <input type="checkbox"/> Missing Form | <input type="checkbox"/> Expenditure Plan incomplete |
| <input type="checkbox"/> Supporting documentation missing | <input type="checkbox"/> Funds will not be obligated by 12/31/2024 |
| <input type="checkbox"/> Project will not be completed by 12/31/2026 | <input type="checkbox"/> Incorrect Signatory |
| <input type="checkbox"/> Ineligible purpose | <input type="checkbox"/> Inconsistent with applicable NN or federal laws |
| <input type="checkbox"/> Submitter failed to timely submit CARES reports | |
| <input type="checkbox"/> Additional information submitted is insufficient to make a proper determination | |

Other Comments: _____

Name of DOJ Reviewer: Veronica Blackhat, Asst Attorney General, Natural Resources Unit

Signature of DOJ Reviewer: 

Disclaimers:
If additional information has been requested and you wish to provide it, please resubmit all the required forms updated to include the additional information. Full resubmission will expedite the Initial Eligibility Determination process. Therefore, please include a new RFS form indicating resubmission, revised Appendix A, Budget Form 1, and other supporting documents. Please email your resubmission to arpa@nndoj.org. Please be aware that under Resolution BFS-31-21 a Project or Program can only be reviewed twice; therefore it is critical that you include all the requested additional information for your second submission.

An NNDNJ Initial Eligibility Determination is based on the documents provided, which NNDNJ will assume are true, correct, and complete. Should the Project or Program change in any material way after the initial determination, the requestor must seek the advice of NNDNJ. An initial determination is limited to review of the Project or Program as it relates to whether the Project or Program is a legally allowable use – it does not serve as an opinion as to whether or not the Project or Program should be funded, nor does it serve as an opinion as to whether or not the amount requested is reasonable or accurate.

**THE NAVAJO NATION
FISCAL RECOVERY FUNDS REQUEST FORM & EXPENDITURE PLAN
FOR GOVERNANCE-CERTIFIED CHAPTERS**

Part 1. Identification of parties:

Governance-Certified Chapter requesting FRF: Naschitti Community Governance (Naschitti Chapter) Data prepared: 11/17/22

Chapter's mailing address: Drawer D, Sheepsprings, NM 87364 phone & email: 505-732-5400
Sheepsprings, NM 87364 website (if any): naschitti@navajochapters.org

This Form prepared by: Carissa Wood phone/email: 505-732-5400
Chapter Manager cwood@nnchapters.org
CONTACT PERSON'S name and title CONTACT PERSON'S info

Title and type of Project: Rural Addressing

Chapter President: Rhonda Herbert phone & email: 505-870-4991 rherbert@naataanti.org

Chapter Vice-President: Kee Y. Gee phone & email: 480-599-8755 kygee@naataanti.org

Chapter Secretary: Orlinda Skyberg phone & email: 214-693-8804 orlin.r.skyberg@gmail.com

Chapter Treasurer: Orlinda Skyberg phone & email: 214-693-8804 orlin.r.skyberg@gmail.com

Chapter Manager or CSC: Carissa Wood phone & email: 505-732-5400 cwood@nnchapters.org

DCD/Chapter ASO: Patricia Begay phone & email: 928-871-7515 pdbegay@nndcd.org

List types of Subcontractors or Subrecipients that will be paid with FRF (if known): _____ document attached

Amount of FRF requested: \$70,000.00 FRF funding period: 10/1/2022 - 9/30/2026
Indicate Project starting and ending/fiscal year data

Part 2. Expenditure Plan details.

(a) Describe the Program(s) and/or Project(s) to be funded, including how the funds will be used, for what purposes, the location(s) to be served, and what COVID-related needs will be addressed:

This project will consist of allocating funds in the amount of \$70,000.00 to purchase signage materials to implement the local community Rural Addressing System and to hire two individuals to install signage and home identifier tags for the Rural Addressing Systems. This system will be a service to the Naschitti community as a whole as it will provide addressing for all homes located within Naschitti boundaries to access the E911 systems and home location identifiers for first responders for emergency situations.

document attached

(b) Explain how the Program or Project will benefit the Navajo Nation, Navajo communities, or the Navajo People:

This project will benefit the Naschitti Community members by providing home address and street names. This system will be a service to the Naschitti community as a whole as it will provide official addressing for all homes located within Naschitti boundaries to access the E911 systems for first responders for emergency situations.

document attached

(c) A prospective timeline showing the estimated date of completion of the Project and/or each phase of the Project. Disclose any challenges that may prevent you from incurring costs for all funding by December 31, 2024 and/or fully expanding funds and completing the Program(s) or Project(s) by December 31, 2028:

APPENDIX A

Current: Complete assessments and identify homes/residents within the Naschitti community boundaries; January 2023 Complete data entry into the Rural Addressing website and verify information with NNAA; July 2023 Purchase signage materials and supplies for all streets and homes on listings ; July 2026 complete final close out of project.

document attached

(d) Identify who will be responsible for implementing the Program or Project:

The Naschitti Community Governance will monitor and keep project on task with Division of Community Development providing oversight.

document attached

(e) Explain who will be responsible for operations and maintenance costs for the Project once completed, and how such costs will be funded prospectively:

The Naschitti Community Governance (Naschitti Chapter) will be responsible for operations and maintenance of the Rural Addressing System in conjunction with Navajo Nation Rural Addressing.

document attached

(f) State which of the 66 Fiscal Recovery Fund expenditure categories in the attached U.S. Department of the Treasury Appendix 1 listing the proposed Program or Project falls under, and explain the reason why:

6.1 Other Public Health Services^A

Naschitti Community Governance (Naschitti Chapter) is respectfully requesting funding to purchase signage materials and supplies to implement our local community Rural Addressing System for access to the E911 system. Two (2) individuals will be hired to install signage and home identifier tags for Rural Addressing System.

document attached

Part 3. Additional documents:

List here all additional supporting documents attached to this FRF Expenditure Plan (or indicate N/A):

**Exhibit B: Budget and Expenditure Plan
Naschitti Community Governance supporting resolution**

Chapter Resolution attached

Part 4. Affirmation by Funding Recipient:

Funding Recipient affirms that its receipt of Fiscal Recovery Funds and the implementation of this FRF Expenditure Plan shall be in accordance with Resolution No. CJY-41-21, the ARPA, ARPA Regulations, and with all applicable federal and Navajo Nation laws, regulations, and policies:

Chapter's Preparer:

CAUSSIN WOOZI
signature of Preparer/CONTACT PERSON

Approved by:

[Signature]
signature of Chapter President or Vice President

Approved by:

CAUSSIN WOOZI
signature of Chapter Manager or LSC

Approved by:

Patricia D. Begay
signature of Director/ASD

Approved to submit for Review:

[Signature]
signature of local leader

FY 2023



THE NAVAJO NATION
PROGRAM BUDGET SUMMARY

Page 1 of 3
BUDGET FORM 1



PART I. Business Unit No.: <u>NEW</u>		Program Title: <u>Naschitti Governance Chapter - Rural Addressing</u>		Division/Branch: <u>DCD/Executive</u>	
Prepared By: <u>Carlssa Wood, Manager</u>		Phone No.: <u>505-732-5400</u>		Email Address: <u>naschitti@navajochapters.org</u>	

PART II. FUNDING SOURCE(S)	Fiscal Year /Term	Amount	% of Total	PART III. BUDGET SUMMARY	Fund Type Code	(A) NNC Approved Original Budget	(B) Proposed Budget	(C) Difference or Total
HN Fiscal Recovery Funds	10/1/22-9/30/28	\$70,000	100%	2001 Personnel Expenses				
				3000 Travel Expenses				
				3500 Meeting Expenses				
				4000 Supplies	8	0	50,800 net	50,800 net
				5000 Lease and Rental				
				5500 Communications and Utilities				
				6000 Repairs and Maintenance	8 net	0 net	20,400 net	20,400 net
				6600 Contractual Services	8	0	19,200 net	19,200 net
				7000 Special Transactions				
				8000 Public Assistance				
				9000 Capital Outlay				
				9500 Matching Funds				
				9900 Indirect Cost				
				TOTAL		\$0.00	\$ 70,000.00	\$ 70,000.00

PART IV. POSITIONS AND VEHICLES	(D)	(E)
Total # of Positions Budgeted:	0	2
Total # of Vehicles Budgeted:	0	0

PART V. I HEREBY ACKNOWLEDGE THAT THE INFORMATION CONTAINED IN THIS BUDGET PACKAGE IS COMPLETE AND ACCURATE.	
SUBMITTED BY: <u>James Adakai, Deputy Director</u> Program Manager's Printed Name  Program Manager's Signature and Date	APPROVED BY: <u>Calvin Castillo, Executive Director</u> Division Director / Branch Chief's Printed Name  Division Director / Branch Chief's Signature and Date

THE NAVAJO NATION
PROGRAM PERFORMANCE CRITERIA

PART I. PROGRAM INFORMATION:									
Business Unit No.: <u>NEW</u>			Program Name/Title: <u>Naschitil Governance Chapter Rural Addressing</u>						
PART II. PLAN OF OPERATION/RESOLUTION NUMBER/PURPOSE OF PROGRAM:									
PART III. PROGRAM PERFORMANCE CRITERIA:									
		1st QTR		2nd QTR		3rd QTR		4th QTR	
		Goal	Actual	Goal	Actual	Goal	Actual	Goal	Actual
1. Goal Statement:									
<u>To purchase materials and Hire 2 individuals to install signage for rural addressing system</u>									
Program Performance Measure/Objective:									
<u>To purchase and install rural addressing signage for Naschitil Community</u>						2			
2. Goal Statement:									
<u> </u>									
Program Performance Measure/Objective:									
<u> </u>									
3. Goal Statement:									
<u> </u>									
Program Performance Measure/Objective:									
<u> </u>									
4. Goal Statement:									
<u> </u>									
Program Performance Measure/Objective:									
<u> </u>									
5. Goal Statement:									
<u> </u>									
Program Performance Measure/Objective:									
<u> </u>									
PART IV. I HEREBY ACKNOWLEDGE THAT THE ABOVE INFORMATION HAS BEEN THOROUGHLY REVIEWED.									
<u>James Adakai, Deputy Director</u> Program Manager's Printed Name				<u>Calvin Castillo, Executive Director</u> Division Director/Branch Chief's Printed Name					
 Program Manager's Signature and Date				 2/8/2023 Division Director/Branch Chief's Signature and Date					

FY 2023
AK

THE NAVAJO NATION
 DETAILED BUDGET AND JUSTIFICATION

PART I. PROGRAM INFORMATION:			
Program Name/Title: <u>Naashonithi Governance Chapter - Rural Addressing</u> <i>AK</i>		Business Unit No.: <u>NAW</u> <i>AK</i>	
PART II. DETAILED BUDGET:			
(A)	(B)	(C)	(D)
Object Code (LOD 6)	Object Code Description and Justification (LOD 7)	Total by DETAILED Object Code (LOD 6)	Total by MAJOR Object Code (LOD 4)
4000 <i>AK</i>	Supplies		50,800 <i>AK</i>
4410 <i>AK</i>	Operating Supplies	49,600 <i>AK</i>	
	4420 General Operating Supplies		
4700 <i>AK</i>	Fuel	1,200 <i>AK</i>	
	4710 Gasoline		
6500 <i>AK</i>	Contractual Services <i>AK</i>		
6520 <i>AK</i>	Consulting <i>AK</i>		19,200 <i>AK</i>
	6530 consulting - Fees <i>AK</i>	9,600 <i>AK</i>	
	6540 consulting - Expenses <i>AK</i>	9,600 <i>AK</i>	
TOTAL		70,000 <i>AK</i>	70,000 <i>AK</i>

**Naschitti Community Governance
Rural Addressing Project Budget**

Signage Material	Qty	Unit Price	Total Price
Shield Sign Intersection Sign Combo	30	\$407.00	\$12,210.00
Cross Intersection	40	\$163.00	\$6,520.00
Structure Identification Sign (w/Non-Flexible delineator post)	450	\$27.00	\$12,150.00
Flexible Delineator Posts	1,000	\$15.00	\$15,000.00

Labor Cost

2 Temp Laborers x \$10.00 per hour x 960 hours = \$19,200.00

Supplies

Gas/Mileage 3750 miles x .32= \$1,200.00
Additional expenses \$3,720.00

Total Cost: \$70,000.00

Naschitti Community Governance

Navajo Nation, Navajo Nation, Navajo Nation
Navajo Nation, Navajo Nation, Navajo Nation



NAS-23-12-006

RESOLUTION OF NASCHITTI COMMUNITY GOVERNANCE

NASCHITTI COMMUNITY GOVERNANCE APPROVES AND ACCEPTS THE SELECTION OF THE AMERICAN RESCUE PLAN ACT (ARPA) - NAVAJO NATION FISCAL RECOVERY FUND EXPENDITURE PLANS FOR THE RURAL ADDRESSING PROJECT IN THE AMOUNT OF \$70,000.00

WHEREAS:

1. Pursuant to N.N.C. Title 26, Chapter 1, Section 3(A), Section 1(B)(1) and Section 1(B)(2) under the Local Government Act, Naschitti Community Governance is a certified local governmental entity of the Navajo Nation and is vested with the authority to address local concerns and the authority to make decisions with responsibility and accountability; and
2. To support the efforts of the Navajo Nation to mitigate the effects of the COVID-19 Pandemic, the ARPA Fiscal Recovery Funds were allocated to develop the basic infrastructure to improve lives of people who have lived without water, electricity and "basic services to support their daily activities, health, and welfare"; and
3. The Navajo Nation Council approved CJN-29-22, in response to the COVID-19 Pandemic in the best interest of the people; "An Action Relating to the Naabiki'iyati' Committee and Navajo Nation Council; Allocating \$1,070,298,867 of Navajo Nation Fiscal Recovery Funds; Approving the Navajo Nation Fiscal Recovery Fund Expenditure Plans for: Chapter Assistance; Public Safety Emergency Communications; E911; Rural Addressing Projects; Cyber Security; Public Health Projects; Economic Development Projects; Hardship Assistance; Water and Wastewater Projects; Broadband Projects; Home Electricity Connection and Electricity Capacity Projects; Housing Projects and Manufactured Housing Facilities; Bathroom Addition Projects; Construction Contingency Funding; and Reduced Administrative Funding; and
4. The Naschitti Community Governance accepts the ARPA-NNFRF allocation in the amount of \$70,000.00 for the Naschitti Community; and
5. The Naschitti Community Governance Administration will be the point of contact for all administrative matters.
6. Naschitti Community Governance (Chapter) affirms that the Chapter will only use awarded Fiscal Recovery Funds and implement this FRF Expenditure Plan in compliance with the ARPA, ARPA Regulations, and with all applicable federal and Navajo Nation laws, regulations, and policies.

Rhonda Herbert
Commissioner

Eric J. Cox
Commissioner

John Snyder
Commissioner

Dash Bryan
Commissioner

Michael Long
Commissioner

Naschitti Community Governance

Navajo Nation
P.O. Box 100000
Flagstaff, AZ 86001-0000



NAS-23-12-006 – Cont'd

NOW, THEREFORE, BE IT RESOLVED THAT:

The Naschitti Community Governance hereby approves and accepts the ARPA – Navajo Nation Fiscal Recovery Fund Expenditure Plans for the selection the Rural Addressing Project in the amount of \$70,000.00.

CERTIFICATION

I, hereby certify that the foregoing Resolution was duly considered by Naschitti Community Governance Commission and moved for adoption by Hoskie Bryant and seconded by Michael Clani at a duly called meeting at Naschitti, (New Mexico) at which a quorum was present and that same was passed by a vote of -4- yeas and -0- nays on this 4th day of December 2022.

Rhonda Herbert, Commission President
Naschitti Community Governance

AMENDED CERTIFICATION

I, hereby certify that the foregoing Resolution was duly considered by Naschitti Community Governance Commission and moved for adoption by Alexis Wood and seconded by Tammy Yazzie at a duly called meeting at Naschitti, (New Mexico) at which a quorum was present and that same was passed by a vote of -3- yeas and -0- nays on this 19th day of February, 2023.

Rhonda Herbert, Commission President
Naschitti Community Governance

**Expenditure Plan-3:
NASCHITTI HOUSE
WIRING**



**NAVAJO NATION DEPARTMENT OF JUSTICE
OFFICE OF THE ATTORNEY GENERAL**

ETHEL B. BRANCH
Attorney General

HEATHER CLAH
Deputy Attorney General

**DEPARTMENT OF JUSTICE
INITIAL ELIGIBILITY DETERMINATION
FOR NAVAJO NATION FISCAL RECOVERY FUNDS**

RFS/HK Review #: HK 0419

Date & Time Received: 3/28/23 at 16:56

Date & Time of Response: 4/11/23 at 502 pm

Entity Requesting FRF: Naschitti Community Governance (Naschitti Chapter)

Title of Project: House Wiring

Administrative Oversight: Division of Community Development

Amount of Funding Requested: \$525,000.00

Eligibility Determination:

- FRF eligible
 FRF ineligible
 Additional information requested

FRF Eligibility Category:

- (1) Public Health and Economic Impact
 (2) Premium Pay
 (3) Government Services/Lost Revenue
 (4) Water, Sewer, Broadband Infrastructure

U.S. Department of Treasury Reporting Expenditure Category: _____

2.18 Housing Support: Other Housing Assistance

Returned for the following reasons (Ineligibility Reasons/Paragraphs 5.E.(1)-(10) of FRF Procedures):

- | | |
|--|--|
| <input type="checkbox"/> Missing Form | <input type="checkbox"/> Expenditure Plan incomplete |
| <input type="checkbox"/> Supporting documentation missing | <input type="checkbox"/> Funds will not be obligated by 12/31/2024 |
| <input type="checkbox"/> Project will not be completed by 12/31/2026 | <input type="checkbox"/> Incorrect Signatory |
| <input type="checkbox"/> Ineligible purpose | <input type="checkbox"/> Inconsistent with applicable NN or federal laws |
| <input type="checkbox"/> Submitter failed to timely submit CARES reports | |
| <input type="checkbox"/> Additional information submitted is insufficient to make a proper determination | |

Other Comments: _____

Name of DOJ Reviewer: Rudy Anaya, Tax and Finance Unit

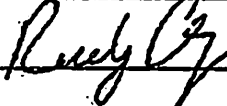
Signature of DOJ Reviewer: 

Disclaimers:
If additional information has been requested and you wish to provide it, please resubmit all the required forms updated to include the additional information. Full resubmission will expedite the Initial Eligibility Determination process. Therefore, please include a new RFS form indicating resubmission, revised Appendix A, Budget Form 1, and other supporting documents. Please email your resubmission to arpa@nndoj.org. Please be aware that under Resolution BFS-31-21 a Project or Program can only be reviewed twice, therefore it is critical that you include all the requested additional information for your second submission.

An NNDNJ Initial Eligibility Determination is based on the documents provided, which NNDNJ will assume are true, correct, and complete. Should the Project or Program change in any material way after the initial determination, the requestor must seek the advice of NNDNJ. An initial determination is limited to review of the Project or Program as it relates to whether the Project or Program is a legally allowable use – it does not serve as an opinion as to whether or not the Project or Program should be funded, nor does it serve as an opinion as to whether or not the amount requested is reasonable or accurate.

**THE NAVAJO NATION
FISCAL RECOVERY FUNDS REQUEST FORM & EXPENDITURE PLAN
FOR GOVERNANCE-CERTIFIED CHAPTERS**

Part 1. Identification of parties.

Governance-Certified Chapter requesting FRF: Naschitti Community Governance (Naschitti Chapter) Date prepared: 11/17/22

Chapter's mailing address: Drawer D, Sheepsprings, NM 87364 phone & email: 505-732-5400
Sheepsprings, NM 87364 website (if any): naschitti@navajochapters.org

This Form prepared by: Carissa Wood phone/email: 505-732-5400
Chapter Manager cwood@nnchapters.org
CONTACT PERSON'S name and title CONTACT PERSON'S title

Title and type of Project: House Wiring

Chapter President: Rhonda Herbert phone & email: 505-870-4991 rherbert@naataanii.org

Chapter Vice-President: Kee Y. Gee phone & email: 480-599-8755 kygee@naataanii.org

Chapter Secretary: Orlinda Skyberg phone & email: 214-693-8804 orlin.r.skyberg@gmail.com

Chapter Treasurer: Orlinda Skyberg phone & email: 214-693-8804 orlin.r.skyberg@gmail.com

Chapter Manager or CSC: Carissa Wood phone & email: 505-732-5400 cwood@nnchapters.org

DCD/Chapter ASO: Patricia Begay phone & email: 928-871-7515 pdbegay@nndcd.org

List types of Subcontractors or Subrecipients that will be paid with FRF (if known): _____

document attached

Amount of FRF requested: \$525,000.00 FRF funding period: 10/1/2022 - 9/30/2026
Indicate Project starting and ending/ending date

Part 2. Expenditure Plan details.

(a) Describe the Program(s) and/or Project(s) to be funded, including how the funds will be used, for what purposes, the location(s) to be served, and what COVID-related needs will be addressed:

This project will consist of allocating funds in the amount of \$525,000.00 for Contractual Services for certified Electricians to install/upgrade house wiring according to Navajo Nation/NTUA code to obtain certified affidavits for electrical hook up. Allocated funds will also include purchasing of electrical materials and supplies as needed.

document attached

(b) Explain how the Program or Project will benefit the Navajo Nation, Navajo communities, or the Navajo People:

This project will benefit the Naschitti Community members by providing adequate house wiring for electrical hook up both independentantly or individuals included in community power line projects which will provide safe and healthy living standards for families who have limited income and resources.



document attached

(c) A prospective timeline showing the estimated date of completion of the Project and/or each phase of the Project. Disclose any challenges that may prevent you from incurring costs for all funding by December 31, 2024 and/or fully expending funds and completing the Program(s) or Project(s) by December 31, 2028:

FY 2023

THE NAVAJO NATION
PROGRAM BUDGET SUMMARY

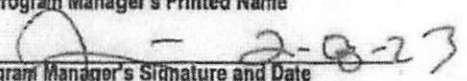
Page 1 of 3
BUDGET FORM 1

PART I. Business Unit No.: <u>NEW</u>		Program Title: <u>Naschilti Governance Chapter - House Wiring</u>		Division/Branch: <u>DCD/Executive</u>					
Prepared By: <u>Carissa Wood, Manager</u>		Phone No.: <u>505-732-5400</u>		Email Address: <u>naschilti@navajochapters.org</u>					
PART II. FUNDING SOURCE(S)	Fiscal Year /Term	Amount	% of Total	PART III. BUDGET SUMMARY		Fund Type Code	(A) NNC Approved Original Budget	(B) Proposed Budget	(C) Difference or Total
NN Fiscal Recovery Funds	10/1/22-9/30/26	\$ 525,000.00	100%	2001 Personnel Expenses					
				3000 Travel Expenses					
				3500 Meeting Expenses					
				4000 Supplies	6	0	225,000	225,000	0
				5000 Lease and Rental					
				5500 Communications and Utilities					
				6000 Repairs and Maintenance					
				6500 Contractual Services	6	0	300,000	300,000	0
				7000 Special Transactions					
				8000 Public Assistance	6	0	225,000	225,000	0
				9000 Capital Outlay					
				9500 Matching Funds					
				9500 Indirect Cost					
				TOTAL		\$0.00	\$ 525,000.00	\$ 525,000.00	
				PART IV. POSITIONS AND VEHICLES		(D)	(E)		
				Total # of Positions Budgeted:		0	0		
				Total # of Vehicles Budgeted:		0	0		
TOTAL:				\$525,000.00	100%				
PART V. I HEREBY ACKNOWLEDGE THAT THE INFORMATION CONTAINED IN THIS BUDGET PACKAGE IS COMPLETE AND ACCURATE.									
SUBMITTED BY: <u>James Adakai, Deputy Director</u>		APPROVED BY: <u>Calvin Castillo, Executive Director</u>							
Program Manager's Printed Name		Division Director / Branch Chief's Printed Name							
 Program Manager's Signature and Date		 Division Director / Branch Chief's Signature and Date							

THE NAVAJO NATION
PROGRAM PERFORMANCE CRITERIA

PART I. PROGRAM INFORMATION:									
Business Unit No.: <u>NEW</u>			Program Name/Title: <u>Naschtiti Governance Chapter House Wiring</u>						
PART II. PLAN OF OPERATION/RESOLUTION NUMBER/PURPOSE OF PROGRAM:									
PART III. PROGRAM PERFORMANCE CRITERIA:									
		1st QTR		2nd QTR		3rd QTR		4th QTR	
		Goal	Actual	Goal	Actual	Goal	Actual	Goal	Actual
1. Goal Statement:									
<u>To purchase supplies and hire electrical contractors to upgrade house wiring for residents.</u>									
Program Performance Measure/Objective:									
<u>To complete House Wiring Project for Naschtiti Community</u>						1			
2. Goal Statement:									

Program Performance Measure/Objective:									

3. Goal Statement:									



Program Performance Measure/Objective:									

4. Goal Statement:									

Program Performance Measure/Objective:									

5. Goal Statement:									

Program Performance Measure/Objective:									

PART IV. I HEREBY ACKNOWLEDGE THAT THE ABOVE INFORMATION HAS BEEN THOROUGHLY REVIEWED.									
<u>James Adakai, Deputy Director</u> Program Manager's Printed Name				<u>Calvin Castillo, Executive Director</u> Division Director/Branch Chief's Printed Name					
 Program Manager's Signature and Date				 Division Director/Branch Chief's Signature and Date					

**THE NAVAJO NATION
DETAILED BUDGET AND JUSTIFICATION**

PART I. PROGRAM INFORMATION:			
Program Name/Title: <u>Naschitl Governance Chapter - House Wiring</u>		Business Unit No.: <u>NEW</u>	
PART II. DETAILED BUDGET:			
(A)	(B)	(C)	(D)
Object Code (LOD 6)	Object Code Description and Justification (LOD 7)	Total by DETAILED Object Code (LOD 6)	Total by MAJOR Object Code (LOD 4)
8300 8500 AT	Public Assistance ^{AT} Infrastructure (non cap) ^{AT} 8530 House Wiring ^{AT} Electrical Wiring Materials & Supplies Purchase materials and electrical supplies to install new/upgrade electrical wiring in community members homes.	\$ 225,000.00	225,000 ^{AT}
6500	CONTRACTUAL SERVICES Hire electrical contractors to install/upgrade electrical wiring in homes for Naschitl community members.	\$ 300,000.00	300,000 ^{AT}
6520 AT	Consulting ^{AT} 6530 Consulting - Fees ^{AT} 6540 Consulting - Expenses ^{AT}	150,000 ^{AT} 150,000 ^{AT}	
TOTAL		\$ 525,000.00	\$ 525,000.00

Naschitti Community Governance

PO Box 100, Shiprock, New Mexico 86530
Phone: 505-733-6400 Fax: 505-733-1100



NAS-23-12-005

RESOLUTION OF NASCHITTI COMMUNITY GOVERNANCE

NASCHITTI COMMUNITY GOVERNANCE APPROVES AND ACCEPTS THE AMERICAN RESCUE PLAN ACT (ARPA) - NAVAJO NATION FISCAL RECOVERY FUND EXPENDITURE PLANS FOR THE HOUSE WIRING PROJECT IN THE AMOUNT OF \$525,000.00

WHEREAS:

1. Pursuant to N.N.C. Title 26, Chapter 1, Section 3(A), Section 1(B)(1) and Section 1(B)(2) under the Local Government Act, Naschitti Community Governance is a certified local governmental entity of the Navajo Nation and is vested with the authority to address local concerns and the authority to make decisions with responsibility and accountability; and
2. To support the efforts of the Navajo Nation to mitigate the effects of the COVID-19 Pandemic, the ARPA Fiscal Recovery Funds were allocated to develop the basic infrastructure to improve lives of people who have lived without water, electricity and "basic services to support their daily activities, health, and welfare"; and
3. The Navajo Nation Council approved CIN-29-22, in response to the COVID-19 Pandemic in the best interest of the people; "An Action Relating to the Naabik'iyaatl' Committee and Navajo Nation Council; Allocating \$1,070,298,867 of Navajo Nation Fiscal Recovery Funds; Approving the Navajo Nation Fiscal Recovery Fund Expenditure Plans for: Chapter Assistance; Public Safety Emergency Communications; E911; Rural Addressing Projects; Cyber Security; Public Health Projects; Economic Development Projects; Hardship Assistance; Water and Wastewater Projects; Broadband Projects; Home Electricity Connection and Electricity Capacity Projects; Housing Projects and Manufactured Housing Facilities; Bathroom Addition Projects; Construction Contingency Funding; and Reduced Administrative Funding; and
4. The Naschitti Community Governance accepts the allocation from the ARPA-NNFRF in the amount of \$525,000.00 for the Naschitti Community; and
5. The Naschitti Community Governance Administration will be the point of contact for all administrative matters.

Thomas G. Smith
Secretary

Ken D. Lee
Commissioner / Tax President

John Shyberq
Commissioner / Secretary / Treasurer

Wesley Bryant
Commissioner / Member

Michael Paul
Commissioner / Member

May 6, 2021

Capital Projects Management Department
Preliminary Cost Breakdown for House Wiring and Meter Loops

Typical 16' X 24' home House Wiring only:

• Materials	\$ 8,500.00
• Labor (Electrician and Helper)	<u>\$ 8,500.00</u>
• Total Cost	\$15,000.00

Meter Loop for Mobile Homes and Hogans:

• Materials	\$ 1,500.00
• Labor	<u>\$ 1,000.00</u>
• Total Cost	\$ 2,500.00

Estimate total cost of \$17,500.00 Per Home.

Naschitti Community Governance

PO Box 100, Shiprock, New Mexico 86501
Phone: 505-324-2102 Fax: 505-324-2100



NAS-23-12-005

RESOLUTION OF NASCHITTI COMMUNITY GOVERNANCE

NASCHITTI COMMUNITY GOVERNANCE APPROVES AND ACCEPTS THE SELECTION OF THE AMERICAN RESCUE PLAN ACT (ARPA) - NAVAJO NATION FISCAL RECOVERY FUND EXPENDITURE PLANS FOR THE HOUSE WIRING PROJECT IN THE AMOUNT OF \$525,000.00

WHEREAS:

1. Pursuant to N.N.C. Title 26, Chapter 1, Section 3(A), Section 1(B)(1) and Section 1(B)(2) under the Local Government Act, Naschitti Community Governance is a certified local governmental entity of the Navajo Nation and is vested with the authority to address local concerns and the authority to make decisions with responsibility and accountability; and
2. To support the efforts of the Navajo Nation to mitigate the effects of the COVID-19 Pandemic, the ARPA Fiscal Recovery Funds were allocated to develop the basic infrastructure to improve lives of people who have lived without water, electricity and "basic services to support their daily activities, health, and welfare"; and
3. The Navajo Nation Council approved CJN-29-22, in response to the COVID-19 Pandemic in the best interest of the people; "An Action Relating to the Naabiki'iyati' Committee and Navajo Nation Council; Allocating \$1,070,298,867 of Navajo Nation Fiscal Recovery Funds; Approving the Navajo Nation Fiscal Recovery Fund Expenditure Plans for: Chapter Assistance; Public Safety Emergency Communications; E911; Rural Addressing Projects; Cyber Security; Public Health Projects; Economic Development Projects; Hardship Assistance; Water and Wastewater Projects; Broadband Projects; Home Electricity Connection and Electricity Capacity Projects; Housing Projects and Manufactured Housing Facilities; Bathroom Addition Projects; Construction Contingency Funding; and Reduced Administrative Funding; and
4. The Naschitti Community Governance accepts the allocation from the ARPA-NNFRF in the amount of \$525,000.00 for the Naschitti Community; and
5. The Naschitti Community Governance Administration will be the point of contact for all administrative matters.
6. Naschitti Community Governance (Chapter) affirms that the Chapter will only use awarded Fiscal Recovery Funds and implement this FRF Expenditure Plan in compliance with the ARPA, ARPA Regulations, and with all applicable federal and Navajo Nation laws, regulations, and policies.

Rhonda Herbert
Commissioner President

Lee J. Cox
Commissioner Vice President

Edin Skybird
Commissioner Secretary/Treasurer

Dorothy Bryant
Commissioner Member

Michael Lewis
Commissioner Member

Naschitti Community Governance

Atlatlat, D. Shoopmitas, New Mexico 87161
Phone: 505 732 5100 Fax: 505 732 5100



NAS-23-12-005 – Cont'd

NOW, THEREFORE, BE IT RESOLVED THAT:

The Naschitti Community Governance hereby approves and accepts the ARPA – Navajo Nation Fiscal Recovery Fund Expenditure Plans for the selection the House Wiring Projects in the amount of \$525,000.00 for the needs of the Naschitti Community.

CERTIFICATION

I, hereby certify that the foregoing Resolution was duly considered by Naschitti Community Governance Commission and moved for adoption by Hoskie Bryant and seconded by Kee Y Gee at a duly called meeting at Naschitti, (New Mexico) at which a quorum was present and that same was passed by a vote of -4- yeas and -0- nays on this 4th day of December 2022.

Rhonda Herbert, Commission President
Naschitti Community Governance

AMENDED CERTIFICATION

I, hereby certify that the foregoing Resolution was duly considered by Naschitti Community Governance Commission and moved for adoption by Orlin Skyberg and seconded by Alexis Wood at a duly called meeting at Naschitti, (New Mexico) at which a quorum was present and that same was passed by a vote of -3- yeas and -0- nays on this 19th day of February, 2023.

Rhonda Herbert, Commission President
Naschitti Community Governance

Rhonda Herbert	Kee Y. Gee	Orlin Skyberg	Hoskie Bryant	Michael C. Gasi
Commission President	Commission Vice-President	Commission Secretary-Treasurer	Commission Member	Commission Member

Appendix E

COUNCIL RESOLUTION

APPROVING

EXPENDITURE PLAN

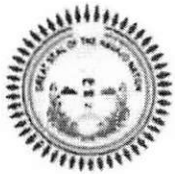

The Navajo Nation **DR. BUU NYGREN** *PRESIDENT*
Yideeskáądi Nitsáhákees **RICHELLE MONTOYA** *VICE PRESIDENT*

May 4, 2023

Honorable Crystalyne Curley, Speaker
Navajo Nation Council
Post Office Box 3390
Window Rock, AZ 86515

RE: *CAP-20-23 An Action Relating to the Naabik'iyáti' Committee and Navajo Nation Council; Approving the Navajo Nation Fiscal Recovery Fund Delegate Regional Project Plan for Honorable Honorable Nathan Notah's Delegate Region (Chapters: Coyote Canyon, Mexican Springs, Naschitti, Tohatchi, Bahastl'a'a')*

Dear Speaker Curley,

I am pleased to sign into law this resolution CAP-20-23 approving the Fiscal Recovery Funds Delegate Regional Project Plan for Honorable Notah's Delegate Region in the amount of \$4,558,189.73.

My Administration supports the plans of these Chapters who have worked very hard to put together their Regional Plans and is working very closely with the Fiscal Recovery Fund Office to ensure that these funds are put to use. As such, when Chapters are running into roadblocks in expending their Fiscal Recovery Funds and the roadblock is coming from the Executive Branch, I encourage them to reach out to the Office of the President and Vice President and inform my office of the roadblock and we will work to overcome those roadblocks.

I do want to take the moment to express my concern that any amendments to the Regional Plans must be approved by the Council. In addition, the prior Navajo Nation Council has set the expectation that Fiscal Recovery Funds be encumbered by June 30, 2024. This deadline is not far off. As a construction expert, I know that there are unpredictable factors that can prevent even the best of plans from moving forward on the proposed timeline. We should be designing systems that are flexible, accountable, and transparent. We do not currently have that system and I look forward to working with you and the entire Council to improve the Navajo Nation systems, so we are supporting our communities to take advantage of this historic funding.

Now let's get to work!

Sincerely,

Dr. Buu Nygren, *President*
THE NAVAJO NATION

**RESOLUTION OF THE
NAVAJO NATION COUNCIL
25th NAVAJO NATION COUNCIL - FIRST YEAR, 2023**

AN ACTION

**RELATING TO THE NAABIK'ÍYÁTI' COMMITTEE AND NAVAJO NATION COUNCIL;
APPROVING THE NAVAJO NATION FISCAL RECOVERY FUND DELEGATE REGION
PROJECT PLAN FOR HONORABLE NATHAN NOTAH'S DELEGATE REGION
(CHAPTERS: COYOTE CANYON, MEXICAN SPRINGS, NASCHITTI, TOHATCHI,
BAHASTL'A'A')**

BE IT ENACTED:

SECTION ONE. AUTHORITY

- A. The Navajo Nation Council is the governing body of the Navajo Nation. 2 N.N.C. § 102(A).
- B. The Naabik'iyáti' Committee is a standing committee of the Navajo Nation Council with the delegated responsibility to hear proposed resolution(s) that require final action by the Navajo Nation Council. 2 N.N.C. § 164(A)(9).
- C. Navajo Nation Council Resolution No. CJN-29-22, incorporated herein by reference, mandates that Navajo Nation Fiscal Recovery Fund ("NNFRF") Delegate Region Project Plans be approved by Navajo Nation Council resolution and signed into law by the President of the Navajo Nation pursuant to 2 N.N.C. § 164(A) and 2 N.N.C. §§ 1005(C)(10), (11), and (12).

SECTION TWO. FINDINGS

- A. The Navajo Nation Council Resolution No. CJN-29-22, AN ACTION RELATING TO THE NAABIK'ÍYÁTI' COMMITTEE AND NAVAJO NATION COUNCIL; ALLOCATING \$1,070,298,867 OF NAVAJO NATION FISCAL RECOVERY FUNDS; APPROVING THE NAVAJO NATION FISCAL RECOVERY FUND EXPENDITURE PLANS FOR: CHAPTER AND REGIONAL PROJECTS; PUBLIC SAFETY EMERGENCY COMMUNICATIONS, E911, AND RURAL ADDRESSING PROJECTS; CYBER SECURITY; PUBLIC HEALTH PROJECTS; HARDSHIP ASSISTANCE; WATER AND WASTEWATER PROJECTS; BROADBAND PROJECTS; HOME ELECTRICITY CONNECTION AND ELECTRIC CAPACITY PROJECTS; HOUSING PROJECTS AND MANUFACTURED HOUSING FACILITIES; BATHROOM ADDITION PROJECTS; CONSTRUCTION CONTINGENCY FUNDING; AND REDUCED ADMINISTRATIVE FUNDING, was signed into law by the President of the Navajo Nation on July 15, 2022.
- B. CJN-29-22, Section Three, states, in part and among other things, that

1. The Navajo Nation hereby approves total funding for the NNFRF Chapter and Chapter Projects Expenditure Plan from the Navajo Nation Fiscal Recovery Fund in the total amount of two hundred eleven million two hundred fifty-six thousand one hundred forty-eight dollars (\$211,256,148) to be divided equally between the twenty-four (24) Delegate Regions in the amount of eight million eight hundred two thousand three hundred forty dollars (\$8,802,340) per Delegate Region . . . and allocated through Delegate Region Project Plans approved by Navajo Nation Council resolution and signed into law by the President of the Navajo Nation . . . See CJN-29-22, Section Three (B).
 2. The Delegate Region Project Plan funding will be allocated to the Navajo Nation Central Government, specifically the Division of Community Development or other appropriate Navajo Nation Division or Department, to implement the projects rather than directly to the Chapters. See CJN-29-22, Section Three (D).
 3. The Navajo Nation Central Government, specifically the Division of Community Development or other appropriate Navajo Nation Division or Department, shall manage and administer funds and Delegate Region Project Plans on behalf of Non-LGA-Certified Chapters. The Navajo Nation Central Government may award funding to LGA-Certified Chapters through sub-recipient agreements to implement and manage specific projects, but shall maintain Administrative Oversight over such funding and Delegate Region Project Plans. See CJN-29-22, Section Three (E).
 4. Each Navajo Nation Council delegate shall select Fiscal Recovery Fund eligible projects within their Delegate Region to be funded by the NNFRF Chapter and Regional Projects Expenditure Plan through a Delegate Region Projects Plan. The total cost of projects selected by each Delegate shall not exceed their Delegate Region distribution of eight million eight hundred two thousand three hundred forty dollars (\$8,802,340). See CJN-29-22, Section Three (F).
 5. Each Delegate Region Project shall identify its Administrative Oversight entity and its Oversight Committee(s) and be subject CJY-41-21's NNDOJ initial eligibility determination. See CJN-29-22, Section Three (L)(5) and (L)(6).
- C. All projects listed in the Hon. Nathan Notah's Delegate Region Projects Plan, attached as Exhibit A, have been deemed Fiscal Recovery Fund eligible by NNDOJ. In addition, Hon. Nathan

Notah's Delegate Region Projects Plan does not exceed the amount of \$8,802,340, as set forth in CJN-29-22, Section Three (F).

- D. The Navajo Nation Council hereby finds that it is in the best interest of the Navajo Nation and the Hon. Nathan Notah's Delegate Region Chapters and communities to approve and adopt the Navajo Nation Fiscal Recovery Fund Delegate Region Project Plan for Hon. Nathan Notah's Delegate Region (Chapters: Coyote Canyon, Mexican Springs, Naschitti, Tohatchi, Bahastl'a'a') as set forth in Exhibit A.

SECTION THREE. APPROVAL OF HON. NATHAN NOTAH'S DELEGATE REGION PROJECT PLAN

- A. The Navajo Nation hereby approves the Fiscal Recovery Fund Delegate Region Project Plan for Hon. Nathan Notah's Delegate Region (Chapters: Coyote Canyon, Mexican Springs, Naschitti, Tohatchi, Bahastl'a'a') set forth in Exhibit A.
- B. The Delegate Region Project Plan approved herein shall comply with all applicable provisions of CJY-41-21, CJN-29-22, and BFS-31-21.
- C. Any inconsistencies between this legislation, the Delegate Region Project Plan, and the individual project appendix, shall be resolved in favor of the project appendix reviewed by Department of Justice during their eligibility determination(s).

SECTION FOUR. AMENDMENTS

Amendments to this legislation or to the Delegate Region Project Plan approved herein shall only be adopted by resolution of the Navajo Nation Council and approval of the President of the Navajo Nation pursuant to 2 N.N.C. § 164(A)(17) and 2 N.N.C. §§ 1005(C)(10), (11), and (12).

SECTION FIVE. EFFECTIVE DATE

This legislation shall be effective upon its approval pursuant to 2 N.N.C. § 221(B), 2 N.N.C. § 164(A)(17), and 2 N.N.C. §§ 1005(C)(10), (11), and (12).

SECTION SIX. SAVING CLAUSE

If any provision of this legislation is determined invalid by the Navajo Nation Supreme Court, or by a Navajo Nation District Court without appeal to the Navajo Nation Supreme Court, those provisions

of this legislation not determined invalid shall remain the law of the Navajo Nation.

CERTIFICATION

I, hereby, certify that the foregoing resolution was duly considered by the 25th Navajo Nation Council at a duly called meeting in Window Rock, Navajo Nation (Arizona), at which a quorum was present and that the same was passed by a vote of 22 in Favor, and 00 Opposed, on this 18th day of April 2023.

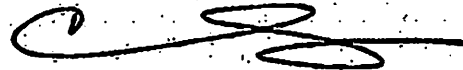

Honorable Crystalyne Curley, Speaker
25th Navajo Nation Council

4/27/23
DATE

Motion: Honorable Rickie Nez
Second: Honorable George H. Tolth

Speaker Crystalyne Curley not voting

ACTION BY THE NAVAJO NATION PRESIDENT:

1. I, hereby, sign into law the foregoing legislation, pursuant to 2 N.N.C. § 1005 (C) (20), on this 5 day of May, 2023.

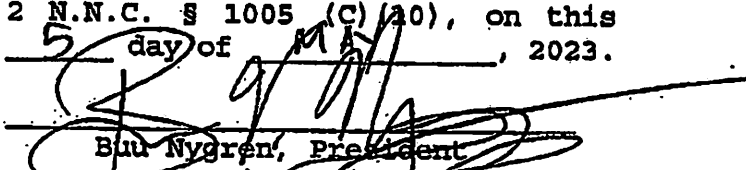
Buu Nygren, President
Navajo Nation

2. I, hereby, veto the foregoing legislation, pursuant to 2 N.N.C. § 1005 (C) (11), on this _____ day of _____, 2023 for the reason(s) expressed in the attached letter to the Speaker.

Buu Nygren, President
Navajo Nation

3. I, hereby, exercise line-item veto pursuant to the budget line-item veto authority delegated to the President by vote of the Navajo People in 2009, on this _____ day of _____, 2023.

Buu Nygren, President
Navajo Nation

NAVAJO NATION FISCAL RECOVERY FUND DELEGATE REGION PROJECT PLAN

Exhibit A

COUNCIL DELEGATE: Delegate Nathan Notah

CHAPTERS: Coyote Canyon, Mexican Springs, Naschitti, Tohatchi, Bahastl'a'a'

FUNDING RECIPIENT	SUBRECIPIENT	EXPENDITURE PLAN / PROJECT	ADMIN OVERSIGHT	FRF CATEGORY	DOJ REVIEW #	AMOUNT
Division of Community Development	None Identified	Coyote Canyon Chapter Motor Grader	Division of Community Development	6.1	HK0360	\$ 433,835.03
Division of Community Development	None Identified	Coyote Canyon Chapter Housing Modernization, Renovation and Weatherization Project	Division of Community Development	2.18	HK0409	\$ 600,000.00
Division of Community Development	None Identified	Coyote Canyon Chapter SYEP and PEP Funding	Division of Community Development	2.37	HK0408	\$ 406,633.00
Division of Community Development	None Identified	Naschitti Chapter Bathroom Additions Project	Division of Community Development	1.14	HK0416	\$ 551,748.70
Division of Community Development	None Identified	Naschitti Chapter Rural Addressing Project	Division of Community Development	1.14	HK0417	\$ 70,000.00
Division of Community Development	None Identified	Twin Lakes Chapter Water and Sewer Infrastructure	Division of Community Development	5.5	HK0456	\$ 200,000.00
Division of Community Development	None Identified	Twin Lakes Chapter Scattered Waterline	Department of Water Resources	5.11	HK0449	\$ 200,000.00
Division of Community Development	None Identified	Tohatchi Chapter Bathroom Additions Project	Division of Community Development	1.14	HK0444	\$ 250,610.00
Division of Community Development	None Identified	Tohatchi Chapter House Wiring Project	Division of Community Development	2.18	HK0443	\$ 91,445.00
Division of Community Development	None Identified	Tohatchi Chapter Septic System and Leach Field Project	Division of Community Development	5.5	HK0446	\$ 950,918.00

*Per CJN-29-22, Section Three (E), the "Navajo Nation Central Government may award funding to LGA-Certified Chapters through sub-recipient agreements to implement and manage specific projects, but shall maintain Administrative Oversight over such funding and Delegate Region Project Plans."

TOTAL: \$ 3,755,189.73

NAVAJO NATION FISCAL RECOVERY FUND DELEGATE REGION PROJECT PLAN

Exhibit A

COUNCIL DELEGATE: Delegate Nathan Notah

CHAPTERS: Coyote Canyon, Mexican Springs, Naschitti, Tohatchi, Bahastl'a'a'

FUNDING RECIPIENT	SUBRECIPIENT	EXPENDITURE PLAN / PROJECT	ADMIN OVERSIGHT	FRF CATEGORY	DOJ REVIEW #	AMOUNT
		TOTAL AMOUNT from PAGE 01				\$ 3,755,189.73
Division of Community Development	None Identified	Tohatchi Chapter Waterline Extension Project	Department of Water Resources	5.11	HK0442	\$ 278,000.00
Division of Community Development	None Identified	Naschitti Chapter House Wiring Project	Division of Community Development	2.18	HK0419	\$ 525,000.00
		UN-ALLOCATED AMOUNT				\$ 4,244,150.27

*Per CJN-29-22, Section Three (E), the "Navajo Nation Central Government may award funding to LGA-Certified Chapters through sub-recipient agreements to implement and manage specific projects, but shall maintain Administrative Oversight over such funding and Delegate Region Project Plans."

TOTAL: \$ 8,802,340.00

Appendix F

FINANCIAL ASSISTANCE AGREEMENT BETWEEN DEPARTMENT OF TREASURY AND THE NAVAJO NATION

OMB Approved No. 1505-0271
Expiration Date: 11/30/2021

U.S. DEPARTMENT OF THE TREASURY
CORONAVIRUS STATE AND LOCAL FISCAL RECOVERY FUNDS

Recipient name and address: The Navajo Nation PO Box 7440 Window Rock, Arizona 86515-7440	DUNS Number: 009001702 Taxpayer Identification Number: 860092335 Assistance Listing Number and Title: 21.027
--	--

Sections 602(b) and 603(b) of the Social Security Act (the Act) as added by section 9901 of the American Rescue Plan Act, Pub. L. No. 117-2 (March 11, 2021) authorizes the Department of the Treasury (Treasury) to make payments to certain recipients from the Coronavirus State Fiscal Recovery Fund and the Coronavirus Local Fiscal Recovery Fund.

Recipients hereby agrees, as a condition to receiving such payment from Treasury, agrees to the terms attached hereto.

Recipient:

Authorized Representative Signature (above)

Authorized Representative Name:

Jonathan Nez

Authorized Representative Title:

President

Date Signed:

U.S. Department of the Treasury:

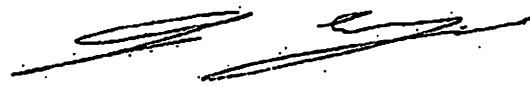

Authorized Representative Signature (above)

Authorized Representative Name:

Jacob Leibentluft

Authorized Representative Title:

Chief Recovery Officer, Office of Recovery Programs

Date Signed:

May 27, 2021

PAPERWORK REDUCTION ACT NOTICE

The information collected will be used for the U.S. Government to process requests for support. The estimated burden associated with this collection of information is 15 minutes per response. Comments concerning the accuracy of this burden estimate and suggestions for reducing this burden should be directed to the Office of Privacy, Transparency and Records, Department of the Treasury, 1500 Pennsylvania Ave., N.W., Washington, D.C. 20220. DO NOT send the form to this address. An agency may not conduct or sponsor, and a person is not required to respond to, a collection of information unless it displays a valid control number assigned by OMB.

**U.S. DEPARTMENT OF THE TREASURY
CORONAVIRUS STATE FISCAL RECOVERY FUND
AWARD TERMS AND CONDITIONS**

1. Use of Funds.

- a. Recipient understands and agrees that the funds disbursed under this award may only be used in compliance with sections 602(c) and 603(c) of the Social Security Act (the Act) and Treasury's regulations implementing that section and guidance.
- b. Recipient will determine prior to engaging in any project using this assistance that it has the institutional, managerial, and financial capability to ensure proper planning, management, and completion of such project.

2. Period of Performance. The period of performance for this award begins on the date hereof and ends on December 31, 2026. As set forth in Treasury's implementing regulations, Recipient may use award funds to cover eligible costs incurred during the period that begins on March 3, 2021 and ends on December 31, 2024.

3. Reporting. Recipient agrees to comply with any reporting obligations established by Treasury, as it relates to this award.

4. Maintenance of and Access to Records

- a. Recipient shall maintain records and financial documents sufficient to evidence compliance with sections 602(c) and 603(c), Treasury's regulations implementing those sections, and guidance regarding the eligible uses of funds.
- b. The Treasury Office of Inspector General and the Government Accountability Office, or their authorized representatives, shall have the right of access to records (electronic and otherwise) of Recipient in order to conduct audits or other investigations.
- c. Records shall be maintained by Recipient for a period of five (5) years after all funds have been expended or returned to Treasury, whichever is later.

5. Pre-award Costs. Pre-award costs, as defined in 2 C.F.R. § 200.458, may not be paid with funding from this award.

6. Administrative Costs. Recipient may use funds provided under this award to cover both direct and indirect costs.

7. Cost Sharing. Cost sharing or matching funds are not required to be provided by Recipient.

8. Conflicts of Interest. Recipient understands and agrees it must maintain a conflict of interest policy consistent with 2 C.F.R. § 200.318(c) and that such conflict of interest policy is applicable to each activity funded under this award. Recipient and subrecipients must disclose in writing to Treasury or the pass-through entity, as appropriate, any potential conflict of interest affecting the awarded funds in accordance with 2 C.F.R. § 200.112.

9. Compliance with Applicable Law and Regulations.

- a. Recipient agrees to comply with the requirements of sections 602 and 603 of the Act, regulations adopted by Treasury pursuant to sections 602(f) and 603(f) of the Act, and guidance issued by Treasury regarding the foregoing. Recipient also agrees to comply with all other applicable federal statutes, regulations, and executive orders, and Recipient shall provide for such compliance by other parties in any agreements it enters into with other parties relating to this award.
- b. Federal regulations applicable to this award include, without limitation, the following:
 - i. Uniform Administrative Requirements, Cost Principles, and Audit Requirements for Federal Awards, 2 C.F.R. Part 200, other than such provisions as Treasury may determine are inapplicable to this Award and subject to such exceptions as may be otherwise provided by Treasury. Subpart F – Audit Requirements of the Uniform Guidance, implementing the Single Audit Act, shall apply to this award.
 - ii. Universal Identifier and System for Award Management (SAM), 2 C.F.R. Part 25, pursuant to which the award term set forth in Appendix A to 2 C.F.R. Part 25 is hereby incorporated by reference.
 - iii. Reporting Subaward and Executive Compensation Information, 2 C.F.R. Part 170, pursuant to which the award term set forth in Appendix A to 2 C.F.R. Part 170 is hereby incorporated by reference.
 - iv. OMB Guidelines to Agencies on Governmentwide Debarment and Suspension (Nonprocurement), 2 C.F.R. Part 180, including the requirement to include a term or condition in all lower tier covered transactions (contracts and subcontracts described in 2 C.F.R. Part 180, subpart B) that the award is subject to 2 C.F.R. Part 180 and Treasury's implementing regulation at 31 C.F.R. Part 19.

- v. Recipient Integrity and Performance Matters, pursuant to which the award term set forth in 2 C.F.R. Part 200, Appendix XII to Part 200 is hereby incorporated by reference.
 - vi. Governmentwide Requirements for Drug-Free Workplace, 31 C.F.R. Part 20.
 - vii. New Restrictions on Lobbying, 31 C.F.R. Part 21.
 - viii. Uniform Relocation Assistance and Real Property Acquisitions Act of 1970 (42 U.S.C. §§ 4601-4655) and implementing regulations.
 - ix. Generally applicable federal environmental laws and regulations.
- c. Statutes and regulations prohibiting discrimination applicable to this award, include, without limitation, the following:
- i. Title VI of the Civil Rights Act of 1964 (42 U.S.C. §§ 2000d et seq.) and Treasury's implementing regulations at 31 C.F.R. Part 22, which prohibit discrimination on the basis of race, color, or national origin under programs or activities receiving federal financial assistance;
 - ii. The Fair Housing Act, Title VIII of the Civil Rights Act of 1968 (42 U.S.C. §§ 3601 et seq.), which prohibits discrimination in housing on the basis of race, color, religion, national origin, sex, familial status, or disability;
 - iii. Section 504 of the Rehabilitation Act of 1973, as amended (29 U.S.C. § 794), which prohibits discrimination on the basis of disability under any program or activity receiving federal financial assistance;
 - iv. The Age Discrimination Act of 1975, as amended (42 U.S.C. §§ 6101 et seq.), and Treasury's implementing regulations at 31 C.F.R. Part 23, which prohibit discrimination on the basis of age in programs or activities receiving federal financial assistance; and
 - v. Title II of the Americans with Disabilities Act of 1990, as amended (42 U.S.C. §§ 12101 et seq.), which prohibits discrimination on the basis of disability under programs, activities, and services provided or made available by state and local governments or instrumentalities or agencies thereto.

10. Remedial Actions. In the event of Recipient's noncompliance with sections 602 and 603 of the Act, other applicable laws, Treasury's implementing regulations, guidance, or any reporting or other program requirements, Treasury may impose additional conditions on the receipt of a subsequent tranche of future award funds, if any, or take other available remedies as set forth in 2 C.F.R. § 200.339. In the case of a violation of sections 602(c) or 603(c) of the Act regarding the use of funds, previous payments shall be subject to recoupment as provided in sections 602(c) and 603(c) of the Act.

11. Hatch Act. Recipient agrees to comply, as applicable, with requirements of the Hatch Act (5 U.S.C. §§ 1501-1508 and 7324-7328), which limit certain political activities of State or local government employees whose principal employment is in connection with an activity financed in whole or in part by this federal assistance.

12. False Statements. Recipient understands that making false statements or claims in connection with this award is a violation of federal law and may result in criminal, civil, or administrative sanctions, including fines, imprisonment, civil damages and penalties, debarment from participating in federal awards or contracts, and/or any other remedy available by law.

13. Publications. Any publications produced with funds from this award must display the following language: "This project [is being] [was] supported, in whole or in part, by federal award number [enter project FAIN] awarded to The Navajo Nation by the U.S. Department of the Treasury."

14. Debts Owed the Federal Government.

- a. Any funds paid to Recipient (1) in excess of the amount to which Recipient is finally determined to be authorized to retain under the terms of this award; (2) that are determined by the Treasury Office of Inspector General to have been misused; or (3) that are determined by Treasury to be subject to a repayment obligation pursuant to sections 602(e) and 603(e) of the Act and have not been repaid by Recipient shall constitute a debt to the federal government.
- b. Any debts determined to be owed the federal government must be paid promptly by Recipient. A debt is delinquent if it has not been paid by the date specified in Treasury's initial written demand for payment, unless other satisfactory arrangements have been made or if the Recipient knowingly or improperly retains funds that are a debt as defined in paragraph 14(a). Treasury will take any actions available to it to collect such a debt.

15. Disclaimer.

- a. The United States expressly disclaims any and all responsibility or liability to Recipient or third persons for the actions of Recipient or third persons resulting in death, bodily injury, property damages, or any other losses resulting in any way from the performance of this award or any other losses resulting in any way from the performance of this award or any contract, or subcontract under this award.
- b. The acceptance of this award by Recipient does not in any way establish an agency relationship between the United States and Recipient.

16. Protections for Whistleblowers.

- a. In accordance with 41 U.S.C. § 4712, Recipient may not discharge, demote, or otherwise discriminate against an employee in reprisal for disclosing to any of the list of persons or entities provided below, information that the employee reasonably believes is evidence of gross mismanagement of a federal contract or grant, a gross waste of federal funds, an abuse of authority relating to a federal contract or grant, a substantial and specific danger to public health or safety, or a violation of law, rule, or regulation related to a federal contract (including the competition for or negotiation of a contract) or grant.
- b. The list of persons and entities referenced in the paragraph above includes the following:
 - i. A member of Congress or a representative of a committee of Congress;
 - ii. An Inspector General;
 - iii. The Government Accountability Office;
 - iv. A Treasury employee responsible for contract or grant oversight or management;
 - v. An authorized official of the Department of Justice or other law enforcement agency;
 - vi. A court or grand jury; or
 - vii. A management official or other employee of Recipient, contractor, or subcontractor who has the responsibility to investigate, discover, or address misconduct.
- c. Recipient shall inform its employees in writing of the rights and remedies provided under this section, in the predominant native language of the workforce.

17. Increasing Seat Belt Use in the United States. Pursuant to Executive Order 13043, 62 FR 19217 (Apr. 18, 1997), Recipient should encourage its contractors to adopt and enforce on-the-job seat belt policies and programs for their employees when operating company-owned, rented or personally owned vehicles.

18. Reducing Text Messaging While Driving. Pursuant to Executive Order 13513, 74 FR 51225 (Oct. 6, 2009), Recipient should encourage its employees, subrecipients, and contractors to adopt and enforce policies that ban text messaging while driving, and Recipient should establish workplace safety policies to decrease accidents caused by distracted drivers.

ASSURANCE OF COMPLIANCE WITH CIVIL RIGHTS REQUIREMENTS

ASSURANCE OF COMPLIANCE WITH TITLE VI OF THE CIVIL RIGHTS ACT OF 1964

As a condition of receipt of federal financial assistance from the Department of the Treasury, the The Navajo Nation (hereinafter referred to as "the Recipient") provides the assurances stated herein. The federal financial assistance may include federal grants, loans and contracts to provide assistance to the recipient's beneficiaries, the use or rent of Federal land or property at below market value, Federal training, a loan of Federal personnel, subsidies, and other arrangements with the intention of providing assistance. Federal financial assistance does not encompass contracts of guarantee or insurance, regulated programs, licenses, procurement contracts by the Federal government at market value, or programs that provide direct benefits. This assurance applies to all federal financial assistance from or funds made available through the Department of the Treasury, including any assistance that the Recipient may request in the future.

The Civil Rights Restoration Act of 1987 provides that the provisions of this assurance apply to all of the recipient's programs, services and activities, so long as any portion of the recipient's program(s) is federally assisted in the manner proscribed above.

1. Recipient ensures its current and future compliance with Title VI of the Civil Rights Act of 1964, as amended, which prohibits exclusion from participation, denial of the benefits of, or subjection to discrimination under programs and activities receiving federal funds, of any person in the United States on the ground of race, color, or national origin (42 U.S.C. § 2000d et seq.), as implemented by the Department of the Treasury Title VI regulations at 31 CFR Part 22 and other pertinent executive orders such as Executive Order 13166; directives; circulars; policies; memoranda and/or guidance documents.
2. Recipient acknowledges that Executive Order 13166, "Improving Access to Services for Persons with Limited English Proficiency," seeks to improve access to federally assisted programs and activities for individuals who, because of national origin, have Limited English proficiency (LEP). Recipient understands that denying a person access to its programs, services, and activities because of LEP is a form of national origin discrimination prohibited under Title VI of the Civil Rights Act of 1964 and the Department of the Treasury's implementing regulations. Accordingly, Recipient shall initiate reasonable steps, or comply with the Department of the Treasury's directives, to ensure that LEP persons have meaningful access to its programs, services, and activities. Recipient understands and agrees that meaningful access may entail providing language assistance services, including oral interpretation and written translation where necessary, to ensure effective communication in the Recipient's programs, services, and activities.
3. Recipient agrees to consider the need for language services for LEP persons during development of applicable budgets and when conducting programs, services and activities. As a resource, the Department of the Treasury has published its LEP guidance at 70 FR 6067. For more information on LEP, please visit <http://www.lep.gov>.
4. Recipient acknowledges and agrees that compliance with this assurance constitutes a condition of continued receipt of federal financial assistance and is binding upon Recipient and Recipient's successors, transferees and assignees for the period in which such assistance is provided.
5. Recipient acknowledges and agrees that it must require any sub-grantees, contractors, subcontractors, successors, transferees, and assignees to comply with assurances 1-4 above, and agrees to incorporate the following language in every contract or agreement subject to Title VI and its regulations between the Recipient and the Recipient's sub-grantees, contractors, subcontractors, successors, transferees, and assignees:

The sub-grantee, contractor, subcontractor, successor, transferee, and assignee shall comply with Title VI of the Civil Rights Act of 1964, which prohibits recipients of federal financial assistance from excluding from a program or activity, denying benefits of, or otherwise discriminating against a person on the basis of race, color, or national origin (42 U.S.C. § 2000d et seq.); as implemented by the Department of the Treasury's Title VI regulations, 31 CFR Part 22, which are herein incorporated by reference and made a part of this contract (or agreement). Title VI also includes protection to persons with "Limited English Proficiency" in any program or activity receiving federal financial assistance; 42 U.S.C. § 2000d et seq., as implemented by the Department of the Treasury's Title VI regulations, 31 CFR Part 22, and herein incorporated by reference and made a part of this contract or agreement.

6. Recipient understands and agrees that if any real property or structure is provided or improved with the aid of federal financial assistance by the Department of the Treasury, this assurance obligates the Recipient, or in the case of a subsequent transfer, the transferee, for the period during which the real property or structure is used for a purpose for which the federal financial assistance is extended or for another purpose involving the provision of similar services or benefits. If any

personal property is provided, this assurance obligates the Recipient for the period during which it retains ownership or possession of the property;

7. Recipient shall cooperate in any enforcement or compliance review activities by the Department of the Treasury of the aforementioned obligations. Enforcement may include investigation, arbitration, mediation, litigation, and monitoring of any settlement agreements that may result from these actions. That is, the Recipient shall comply with information requests, on-site compliance reviews, and reporting requirements.
8. Recipient shall maintain a complaint log and inform the Department of the Treasury of any complaints of discrimination on the grounds of race, color, or national origin, and limited English proficiency covered by Title VI of the Civil Rights Act of 1964 and implementing regulations and provide, upon request, a list of all such reviews or proceedings based on the complaint, pending or completed, including outcome. Recipient also must inform the Department of the Treasury if Recipient has received no complaints under Title VI.
9. Recipient must provide documentation of an administrative agency's or court's findings of non-compliance of Title VI and efforts to address the non-compliance, including any voluntary compliance or other agreements between the Recipient and the administrative agency that made the finding. If the Recipient settles a case or matter alleging such discrimination, the Recipient must provide documentation of the settlement. If Recipient has not been the subject of any court or administrative agency finding of discrimination, please so state.
10. If the Recipient makes sub-awards to other agencies or other entities, the Recipient is responsible for ensuring that sub-recipients also comply with Title VI and other applicable authorities covered in this document. State agencies that make sub-awards must have in place standard grant assurances and review procedures to demonstrate that they are effectively monitoring the civil rights compliance of sub-recipients.

The United States of America has the right to seek judicial enforcement of the terms of this assurance document and nothing in this document alters or limits the federal enforcement measures that the United States may take in order to address violations of this document or applicable federal law.

Under penalty of perjury, the undersigned official(s) certifies that he/she has read and understood its obligations as herein described, that any information submitted in conjunction with this assurance document is accurate and complete, and that the Recipient is in compliance with the aforementioned nondiscrimination requirements.

Recipient

Date

Signature of Authorized Official:

PAPERWORK REDUCTION ACT NOTICE

The information collected will be used for the U.S. Government to process requests for support. The estimated burden associated with this collection of information is 15 minutes per response. Comments concerning the accuracy of this burden estimate and suggestions for reducing this burden should be directed to the Office of Privacy, Transparency and Records, Department of the Treasury, 1500 Pennsylvania Ave., N.W., Washington, D.C. 20220. DO NOT send the form to this address. An agency may not conduct or sponsor, and a person is not required to respond to, a collection of information unless it displays a valid control number assigned by OMB.

Appendix G

**U.S. DEPARTMENT OF
TREASURY**

**COMPLIANCE AND
REPORTING GUIDANCE
FOR SLFRF**